

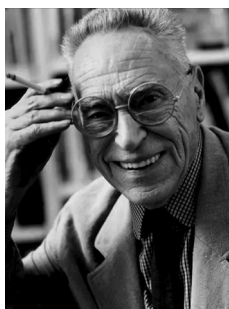

Libreria Pensile

Design Achille and Pier Giacomo Castiglioni

Year 1957



Achille Castiglioni

Renowned Italian designer Achille Castiglioni (1918-2002) had a passion for re-designing, re-inventing and re-conceptualizing. Traditional interior design objects would pass through his Milan-based studio and end up perfected. He always aimed at enhancing and glorifying the value of the design. Throughout his career he worked to raise design to an ever-higher level of synthesis - stripping design down to the very core and eliminating everything superfluous. During his career Achille Castiglioni collaborated with many designers, among them Giancarlo Poggi. Together they made Trio and Comodo in 1991.



Pier Giacomo Castiglioni

The Italian designer and architect Pier Giacomo Castiglioni is the second of the three Castiglioni brothers. Like his brothers, Pier Giacomo Castiglioni studied architecture at Milan Polytechnic. In 1938 Pier Giacomo Castiglioni and his elder brother, Livio, founded a practice in Milan, which the youngest brother, Achille, joined in 1944. All three Castiglioni brothers were interested in both technology and art. Pier Giacomo Castiglioni is regarded as the intellectual equal of his brother Achille. Until his untimely death in 1968, Pier Giacomo collaborated with Achille on numerous objects; Rampa and Libreria Pensile among others. The Castiglioni brothers exerted a strong influence on the younger generation of Italian designers. Pier Giacomo Castiglioni taught design at Milan Polytechnic from 1946 until his passing.



Originally designed in 1957, perfected over the years, and produced by Bernini in 1966. Seeking to pare down the structure of a bookcase to the absolute minimum, Castiglioni decided to hang the shelves on knots in two cords fixed to a single point on the wall.

50 years after it was launched it is still relevant, elegant, and very Castiglioni.

PRODUCT DATA

Design	Achille and Pier Giacomo Castiglioni. 1957
Product type	Shelving unit
Environment	Indoor
Materials	Solid oak, black stained and lacquered or clear lacquered.

DELIVERY

Lead time	Stock (if backorder: 12 weeks)
-----------	--------------------------------

MAXIMUM RECOMMENDED LOADS

Wall type	Max load (KG)
Gypsum, double sheet	2 kg/shelf
Hollow clay brick	3 kg/shelf
Solid clay brick	13 kg/shelf
Concrete	20 kg/shelf

ARTICLE CODES

201463	Libreria Pensile, black stained oak
201464	Libreria Pensile, natural oak

Finishes

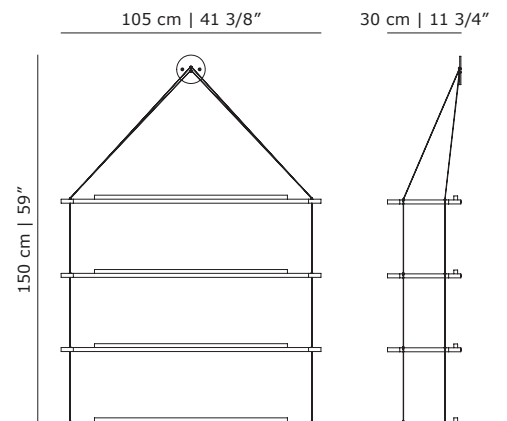



Founded on rebellious curiosity and a passion for the unique, Karakter is a bit out of the ordinary. Rooted in the proud Danish design tradition, but always maintaining an international outlook, Karakter presents a striking portfolio of furniture, lighting and objects from designers who have already written the history of design to those who are aspiring to write the future. All designers collaborating with Karakter are curated for their ideas and creativity and shared by all of them is an inspiring level of curiosity and an uncompromising take on their work. Boasting both the relevant and honest, the beautiful, the playful and the expressive, all designs have a clear, undeniable character. Ready to spark curiosity and start conversations.

Head Office

Karakter
Gammel Lundtoftevej 1C
2800 Kongens Lyngby
Denmark

T +45 38 41 41 31
@karaktercopenhagen
info@karakter-copenhagen.com

Showroom - Paris

Karakter
242 Bis bd st Germain
75007 Paris
France

T +33 01 43 25 48 05
karakterparis@cassina.com

Karakter Corner - Milan

Cassina Showroom
Via Durini, 16
20122 Milano
Italy

T +39 02 76 02 07 45

