



Cassina iMaestri Collection
Collection Le Corbusier®, Pierre Jeanneret®,
Charlotte Perriand®

Designed by
Le Corbusier, Pierre Jeanneret,
Charlotte Perriand, 1928

Produced
Cassina, 2011

Adaptation de Charlotte Perriand
pour Cassina en 1978



Cassina iMaestri Collection
Collection Le Corbusier®, Pierre Jeanneret®,
Charlotte Perriand®

Designed by
Le Corbusier, Pierre Jeanneret,
Charlotte Perriand, 1928

Produced
Cassina, 2019



Struttura

- Telaio in tubolare d'acciaio INOX AISI 304 verniciato nei colori indicati a listino.
- Imbottitura cuscini
- Poliuretano schiumato con inserto in poliuretano espanso.
- Ovatta in fibra di poliestere resinata accoppiata con tela idrorepellente.
- Rivestimento
- Tessuto outdoor.
- Telaio seduta
- In acciaio INOX AISI 304 verniciato nei colori elencati a listino e dotato di cinghiatura elastica specifica per outdoor.
- Piedini
- In materiale plastico nero.

Structure

- Frame in tubular AISI 304 stainless steel, painted in the colours shown on the price list.
- Cushion padding
- Polyurethane foam fill with polyurethane foam insert.
- Resin-treated polyester fibre batting laminated to water-repellent fabric.
- Upholstery
- Outdoor fabric.
- Seat frame
- In AISI 304 stainless steel and outdoor-rated elastic webbing, painted in the colours shown on the price list.
- Feet
- In black plastic.

Gestell

- Rahmen aus Hohlprofil aus Edelstahl AISI 304 mit Lackierung in den Farben nach Preisliste.
- Polsterung Kissen
- PU-Schaum mit Einsatz aus PU-Hartschaum.
- Polsterwatte aus Polyesterharzfasern mit wasserabweisender Stoffhülle.
- Bezug
- Outdoor-Stoff.
- Rahmen Sitzfläche
- Aus Edelstahl AISI 304 mit Lackierung in den Farben nach Preisliste und mit elastischen Riemen speziell für Outdoor.
- Gleiter
- Aus schwarzem Kunststoff.

Structure

- Cadre en acier inoxydable AISI 304 tubulaire, peint dans les couleurs disponibles dans la liste des produits.
- Rembourrage des coussins
- Polyuréthane injecté avec insert en mousse polyuréthane.
- Multicouche en ouate de fibre de polyester résinée et toile déperlante.
- Revêtement
- Tissu d'extérieur.
- Cadre de l'assise
- En acier inoxydable AISI 304 peint dans les couleurs disponibles dans la liste des produits et équipé de sangles élastiques spécifiques pour l'extérieur.
- Embouts de pieds
- En matériau plastique noir.

003 T1 _

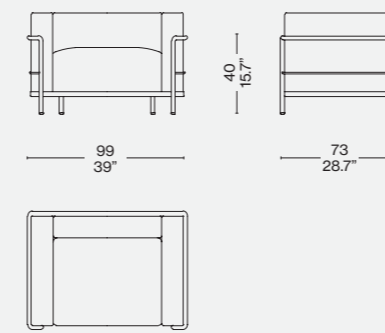

003 T2 _

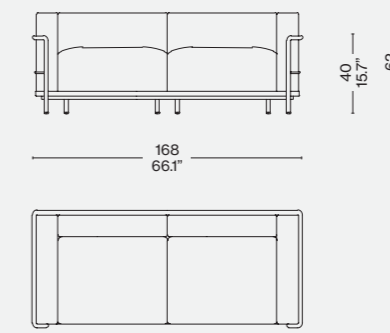

003 T3 _

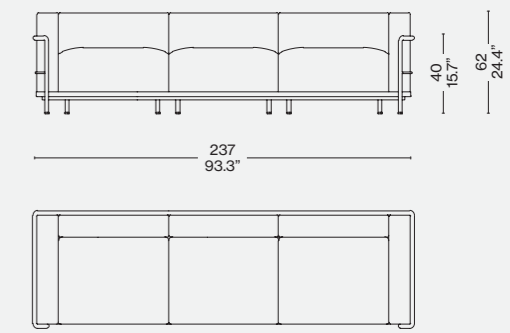

Rivestimento/Upholstery/ Bezug/Revêtement



a

Struttura verde gofrato/Textured green structure/Gestell grün texturiert/Structure vert texturé — Kemi 13L366



b

Struttura marrone gofrato/Textured brown structure/Gestell braun texturiert/Structure marron texturé — Kemi 13L363



c

Struttura avorio gofrato/Textured ivory structure/Gestell elfenbeinweiß texturiert/Structure ivoire texturé — Kemi 13L363



d

Struttura fango gofrato/Textured mud structure/Gestell schlamm texturiert/Structure taupe texturé — Kemi 13L364



Identifying marks and production numbers

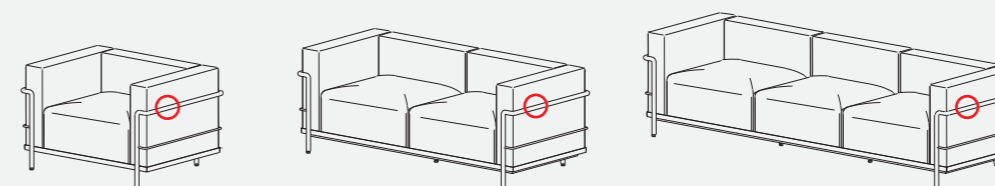

Cassina  LC PJ CP N°..... *Le Corbusier® Jean Prouvé® Charlotte Perriand®*