

Cassina

241 PRIVÈ POLTRONA

Cataloghi I **Contemporanei**

Anno di produzione **2007**

Composta e formale nella sua articolazione, la collezione Privé racchiude in sé elementi di stile e trasgressione che si confondono, confl uendo in un suadente mix di classicismo, provocazione e ironia. La collezione è costituita da diversi modelli - poltrone, divani, isole di diverse dimensioni - ed è caratterizzata dal rivestimento esclusivamente in pelle capitonné, per il quale Cassina ha messo a punto una nuova tecnica di aggancio dei caratteristici bottoni in pelle. Questo sistema, brevettato a livello internazionale, garantisce qualità e durata. Privé ben si adatta ad ambienti rigorosi, pur essendo anche in grado di calarsi agevolmente in ambienti contemporanei ed informali.

Gallery



Dimensioni

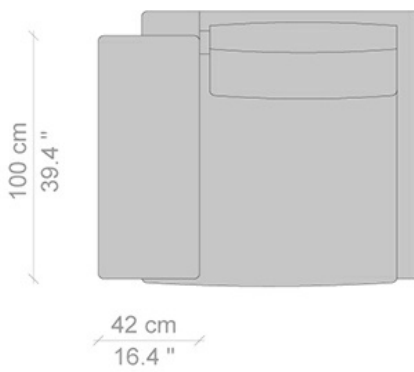
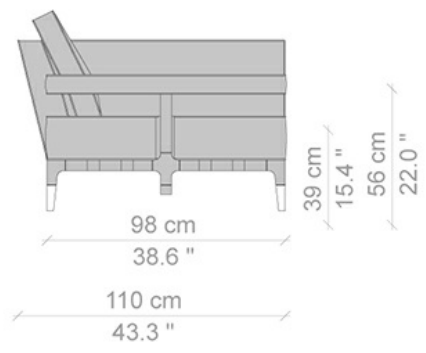
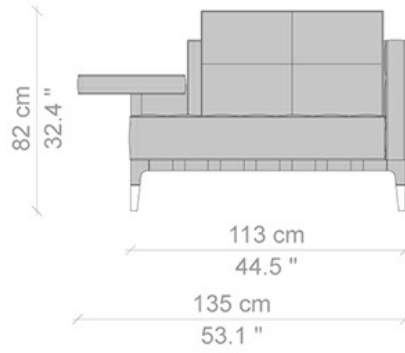
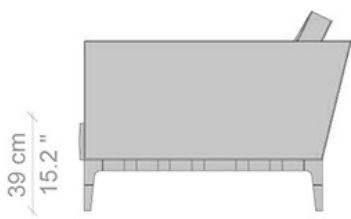
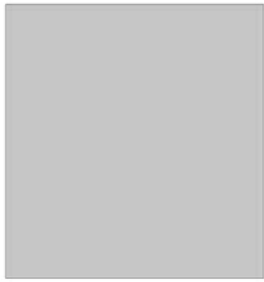
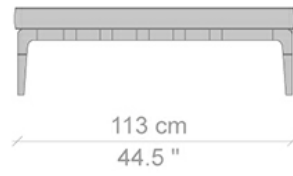
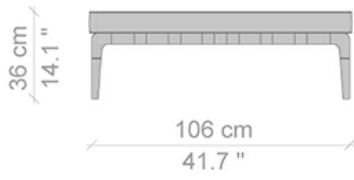

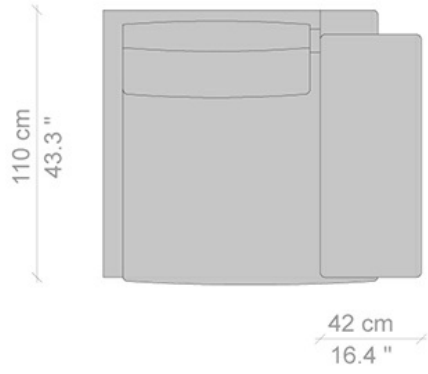
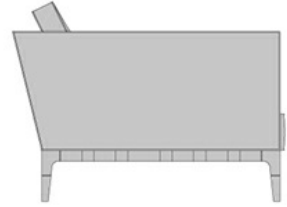
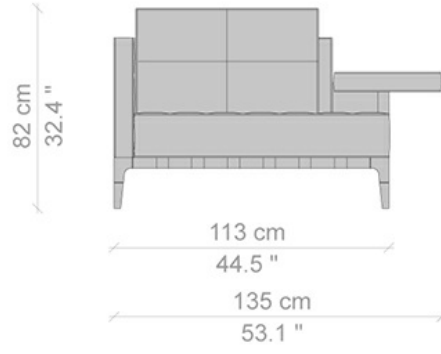
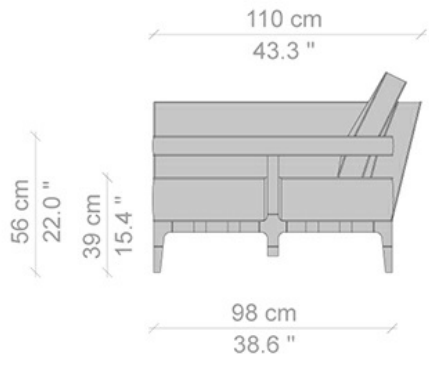

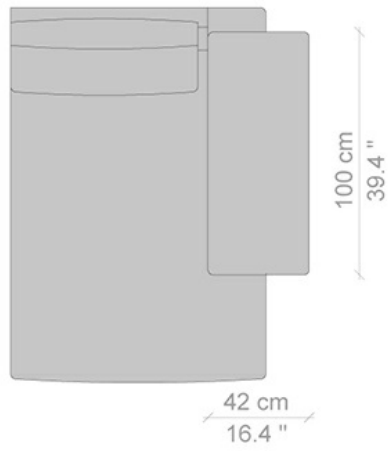
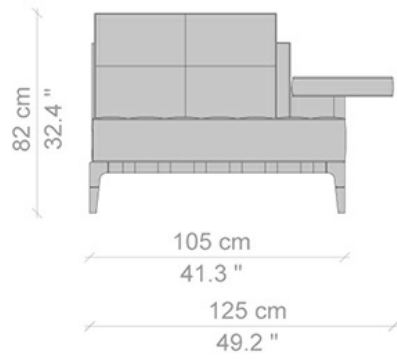
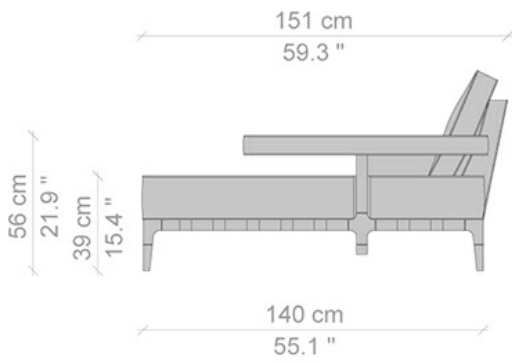

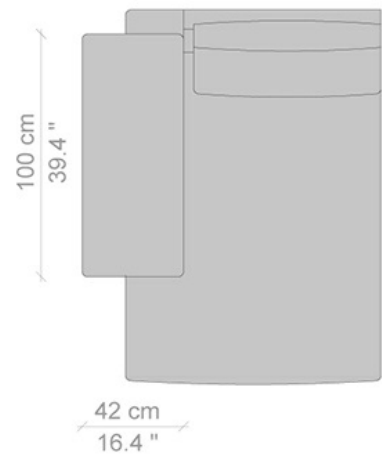
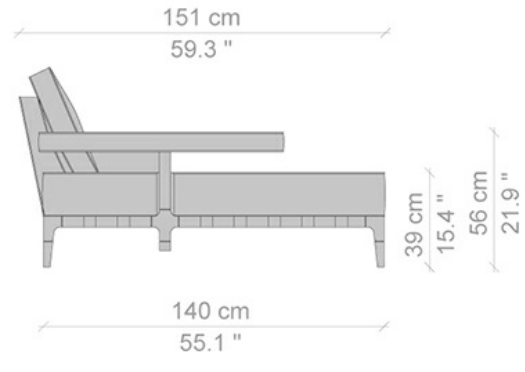
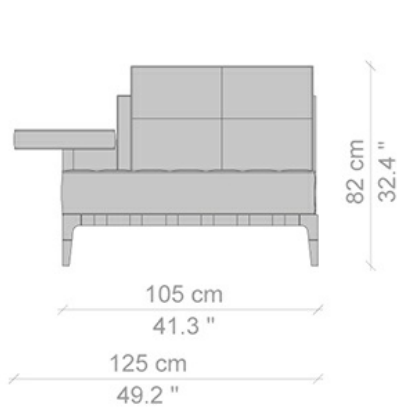

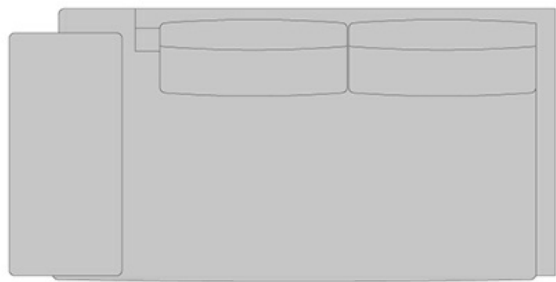
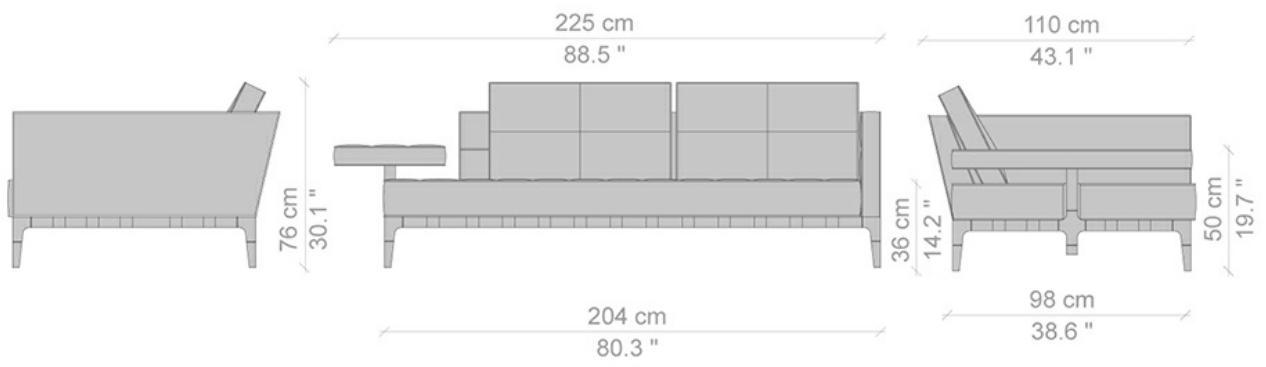

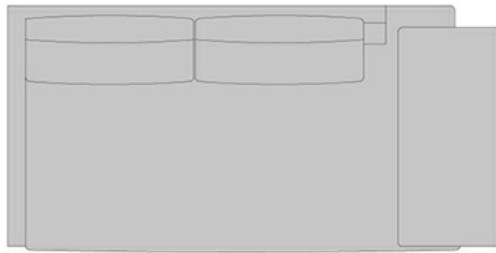
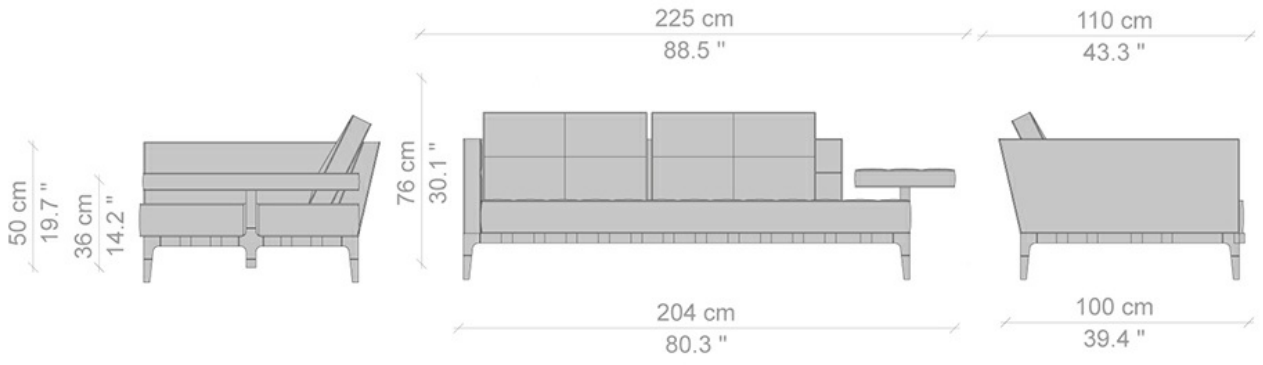

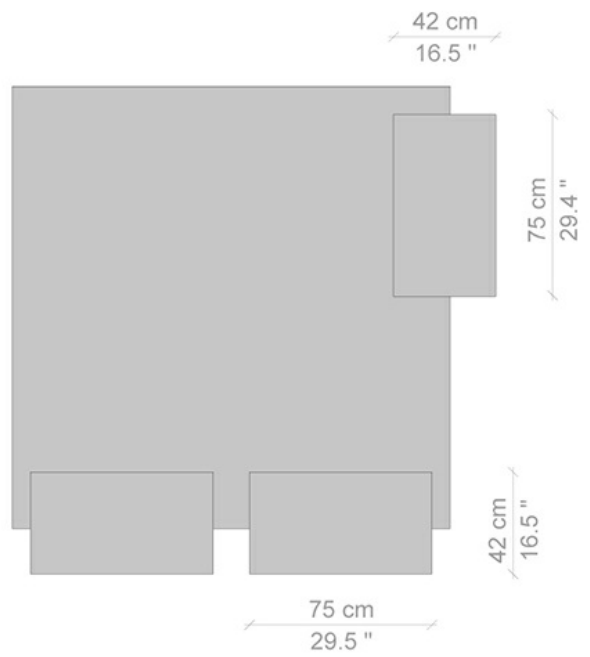
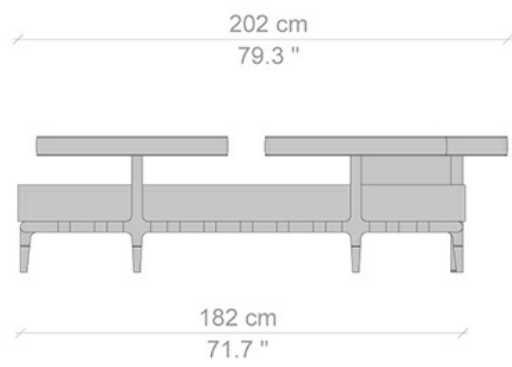
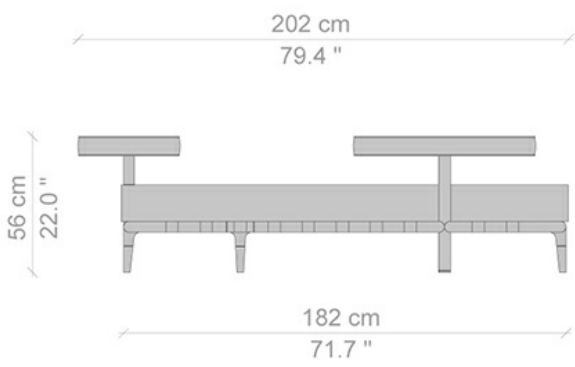

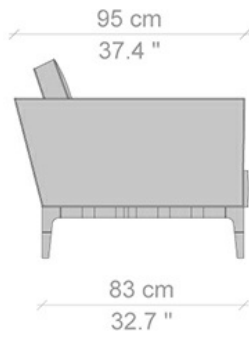
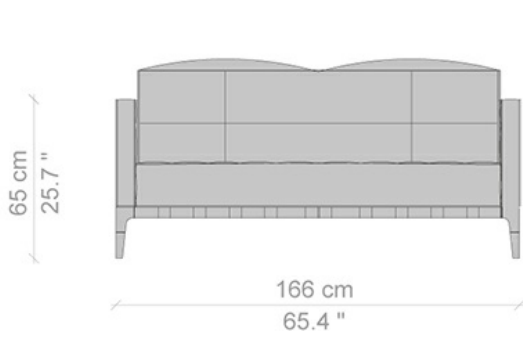
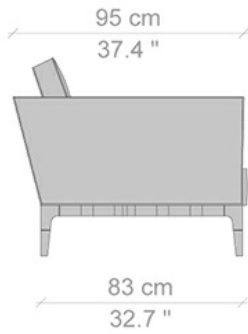
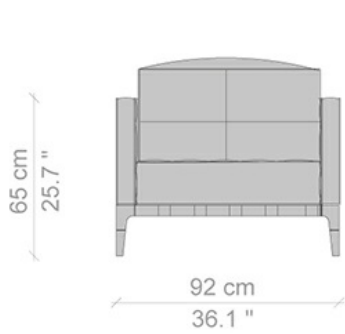
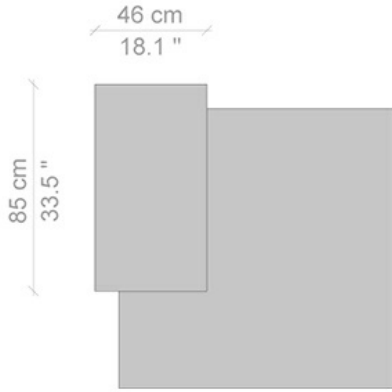
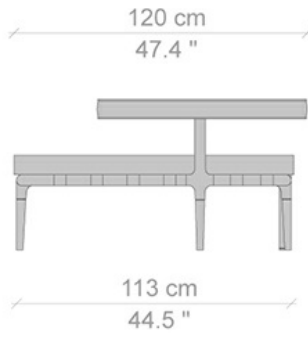
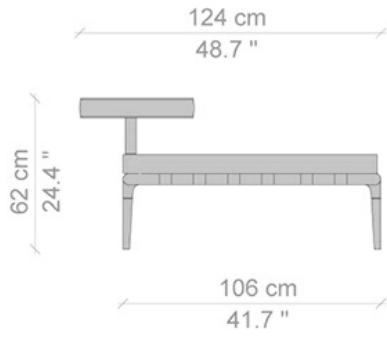

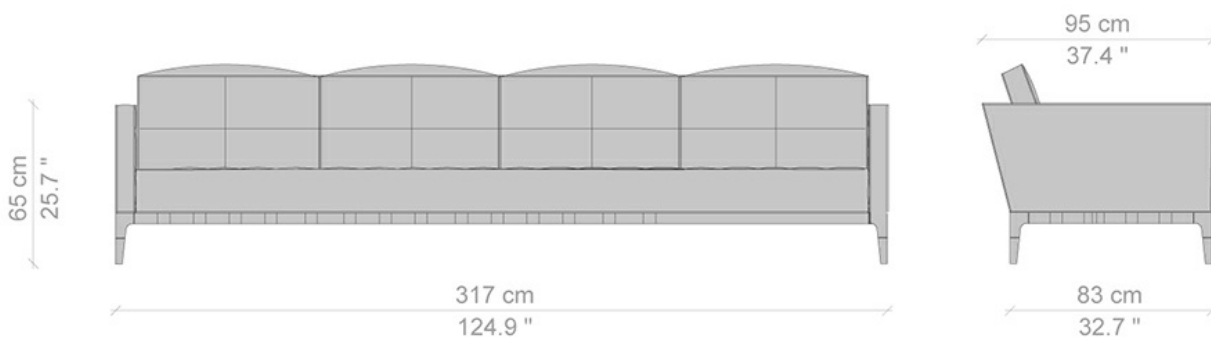
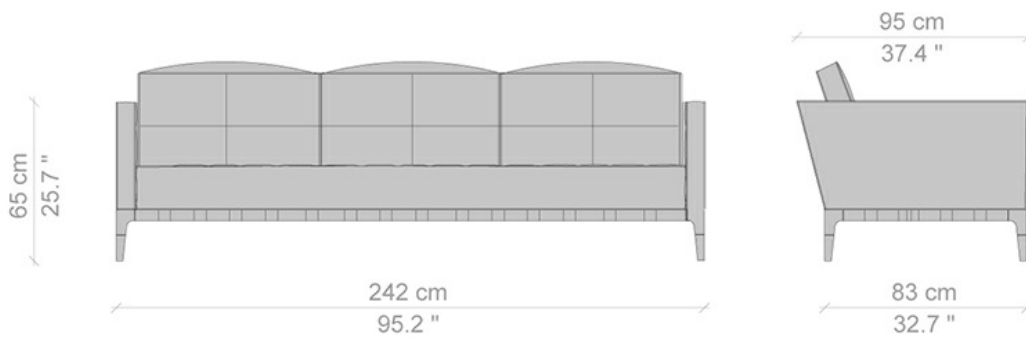

Designer



Philippe Starck

Figlio di un costruttore aeronautico, Philippe Starck nasce a Parigi nel 1949. A vent'anni è direttore artistico di Cardin, a venticinque fa il giro del mondo e si stabilisce negli Usa, a ventisette rientra a Parigi e progetta il primo grande "hard" night club: La main bleu. Seguono altri club, caffè, ristoranti, magazzini, alberghi, i saloni di Pierre Balmain e l'appartamento di François Mitterrand all'Eliseo. Disegna una collezione di mobili per il Ministero della cultura francese, crea il Royalton Hotel a New York, costruisce in Giappone due grandi palazzi, Nani Nani e Asahi, crea il Tétriz a Madrid, il Paramount Hotel a New York, il Baron Vert, uno stabile ancora più stupefacente in Osaka, vince il concorso per l'Ecole Nationale des Arts Décoratifs a Parigi, prepara il nuovo Tétriz in Messico, un nuovo hotel a Miami e molti altri progetti in tutto il mondo. Ma trova anche il tempo per disegnare pasta, barche, posaceneri, lampade, spazzolini da denti, maniglie, spremiagrumi, posate, orologi, scooters, uffici, letti, contenitori termici, giocattoli, bagni, televisori, radio... in breve, tutto il possibile. I musei si contendono le sue opere, sulle quali piovono i più prestigiosi premi e riconoscimenti. Starck prende tutti con sé nel suo cammino, pochi sanno resistere alle sue intelligenti provocazioni. La collaborazione con Cassina inizia negli anni Novanta e si traduce in prodotti davvero innovativi, dagli sviluppi tipologici sorprendenti.