

Cassina

185-186 TOOT

Famiglia TOOT

Cataloghi I Contemporanei

Anno di produzione 2009

Sistema di sedute con elementi base, panca e pannelli, a formare svariate configurazioni: con o senza sponde, tutto aperto e senza schienale, oppure tutto chiuso con cuscini. Cuscini schienale in piuma, in diverse dimensioni, con inserto in poliuretano espanso. Seduta, sostenuta da cinghie, in poliuretano espanso privo di CFC a densità differenziata con imbottitura in piuma. Cavalletti in pressofusione di alluminio lucido. Rivestimento disponibile in tessuto o pelle. Complementi: tavolini quadrati o rettangolari, con stessa struttura del divano e piano in cristallo.

Gallery



Dimensioni

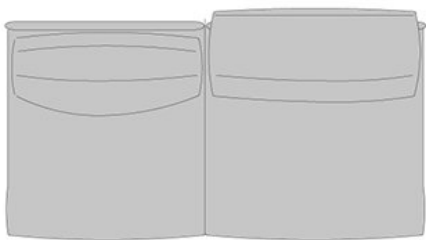
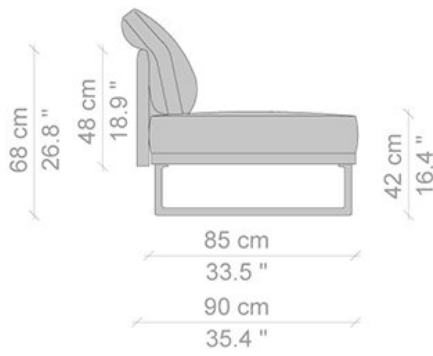
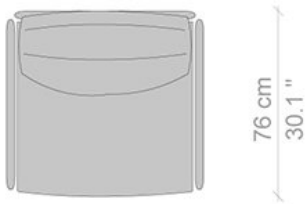
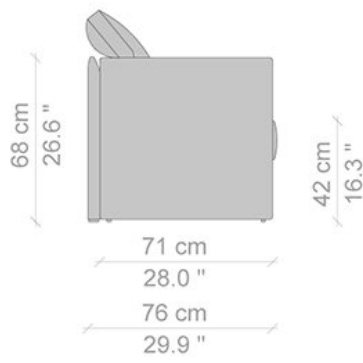

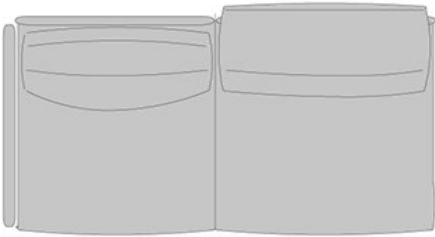
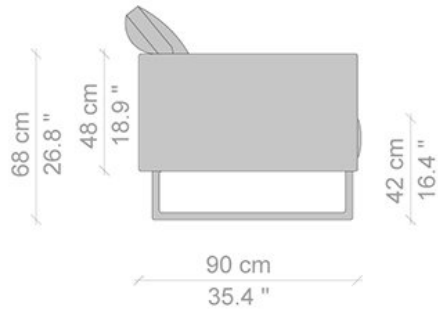
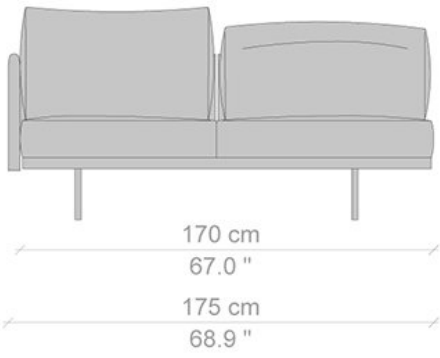

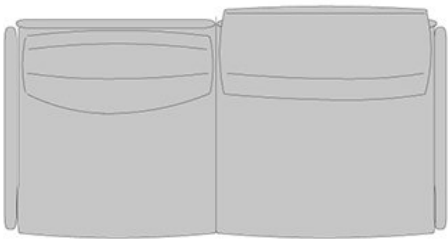
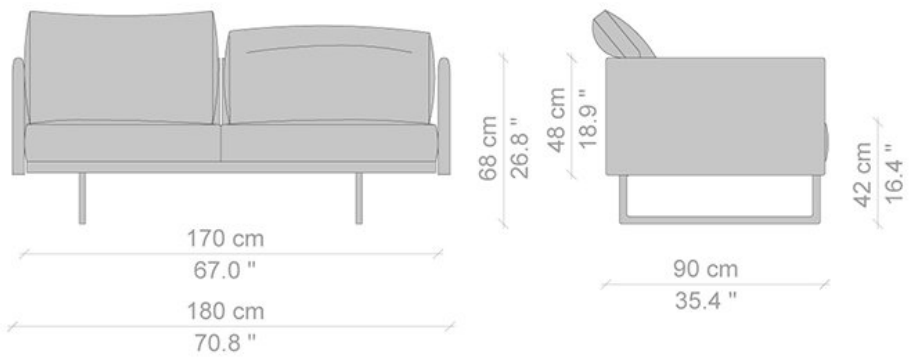

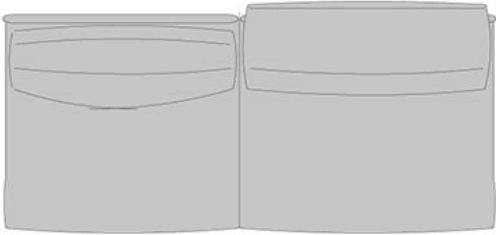
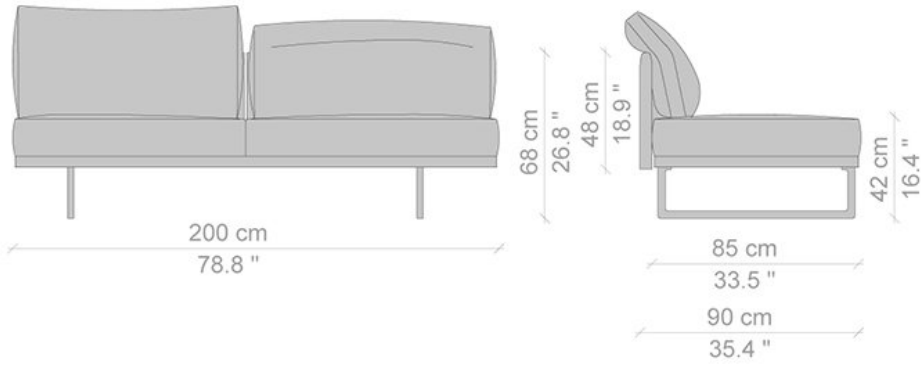

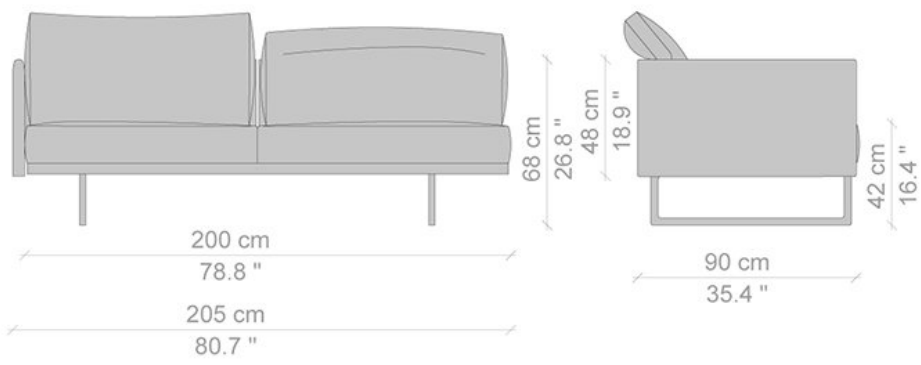

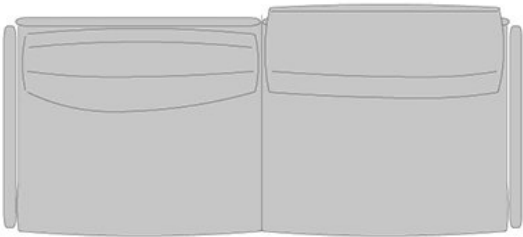
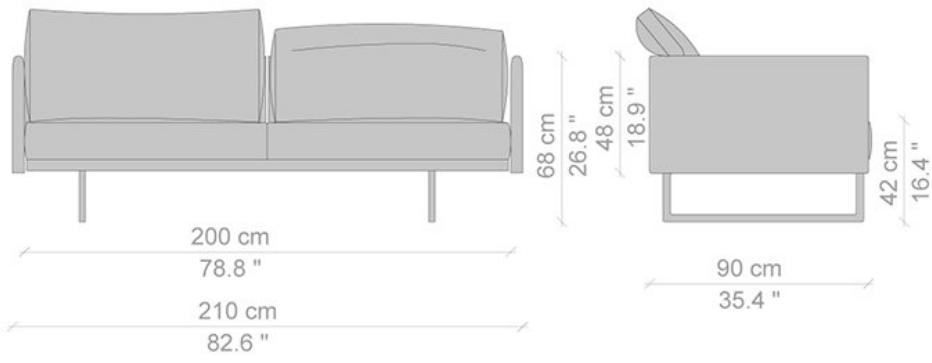

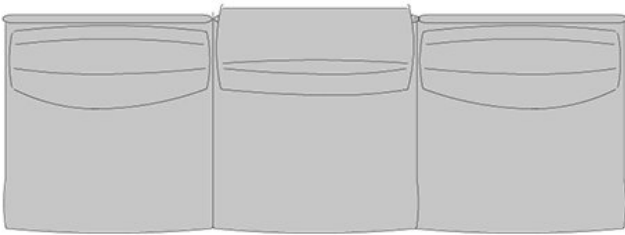
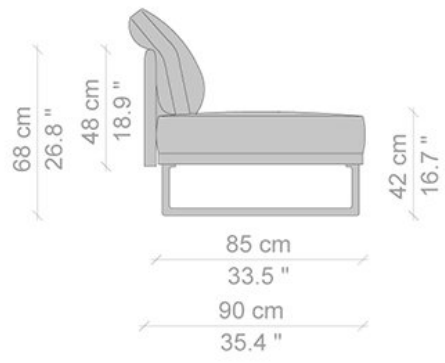
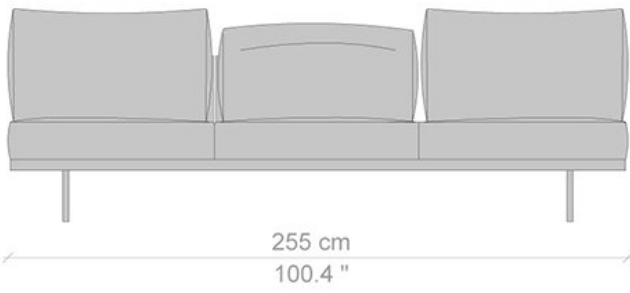

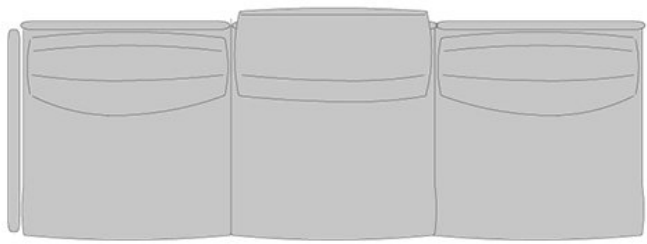
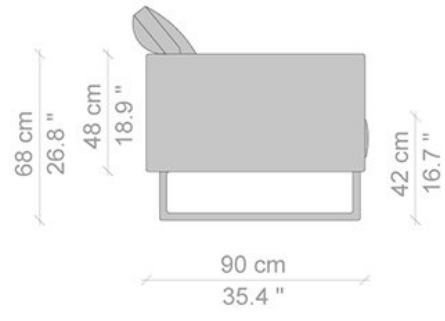
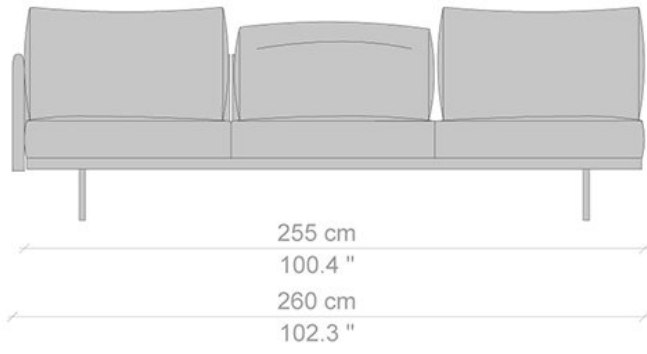

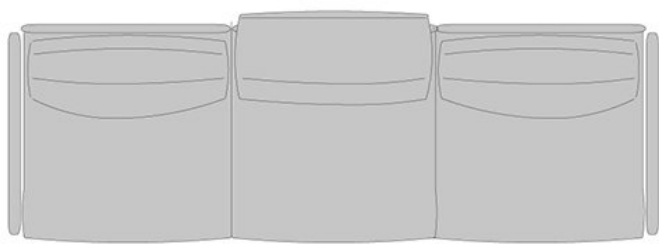
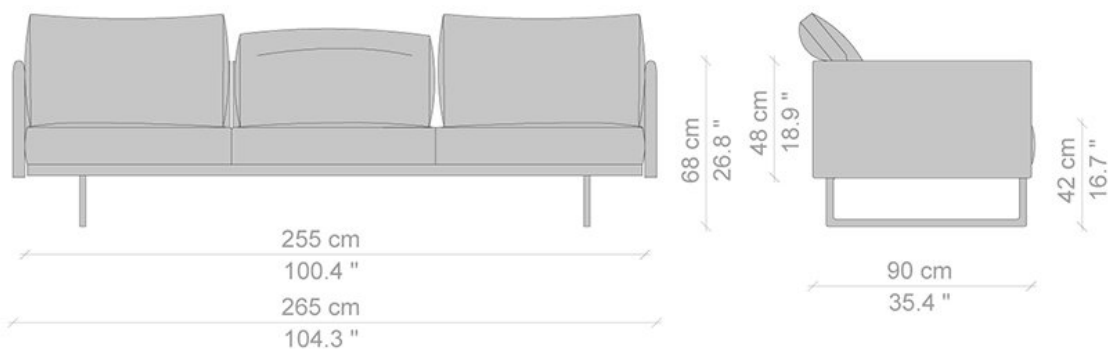

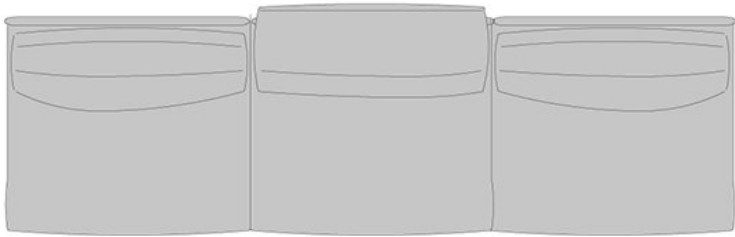
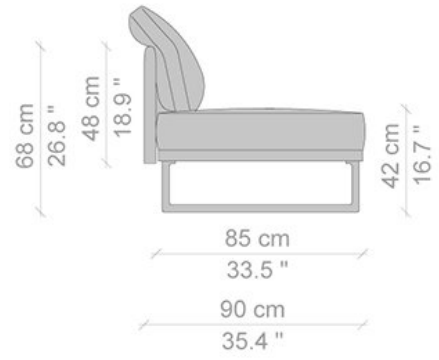
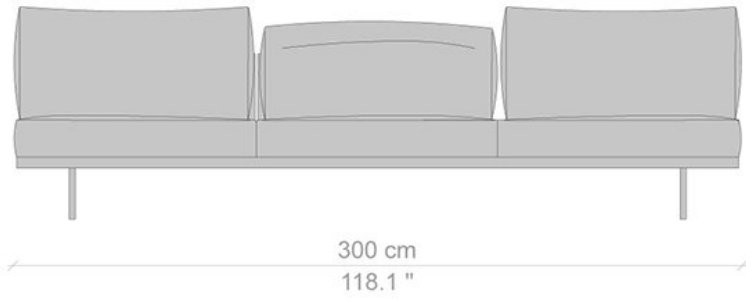

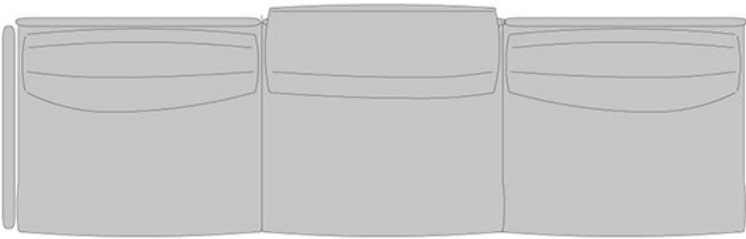
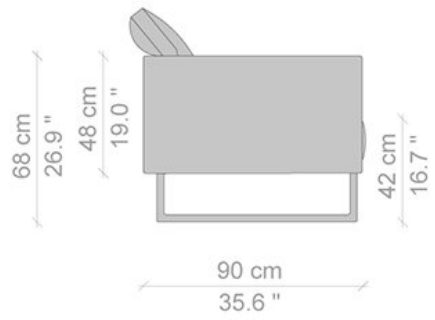
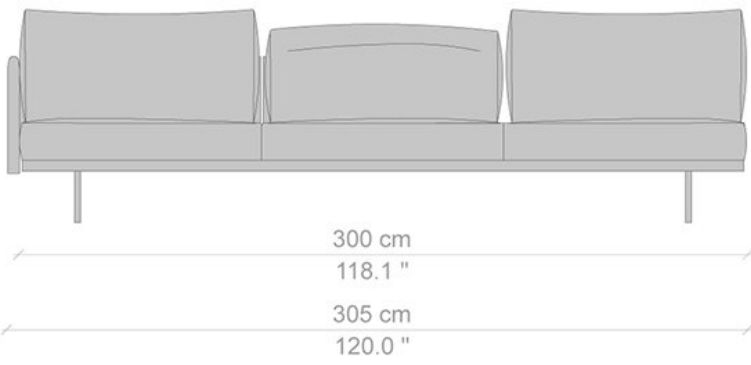

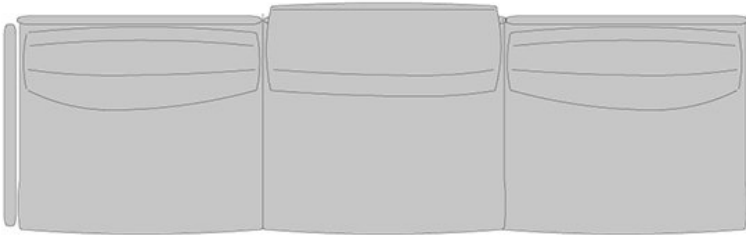
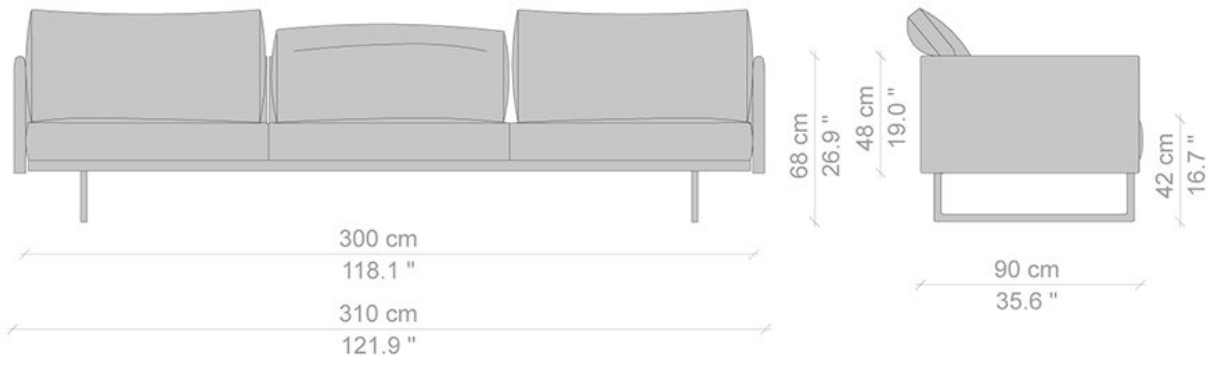



68 cm
26.7 "

48 cm
19.0 "

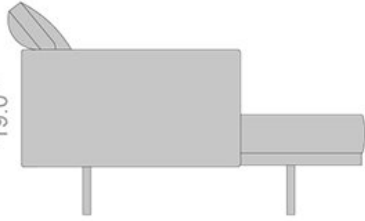

42 cm
16.7 "

140 cm
55.1 "

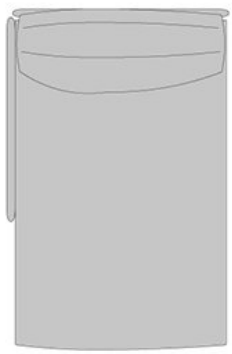

140 cm
55.3 "

85 cm
33.4 "

90 cm
35.6 "

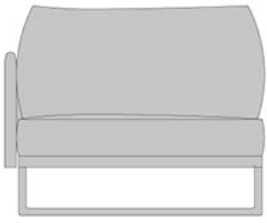

68 cm
26.7 "

48 cm
19.0 "

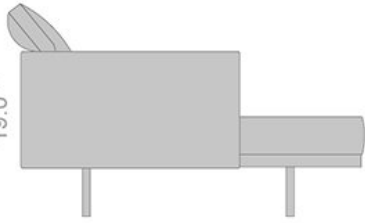

140 cm
55.1 "

42 cm
16.7 "

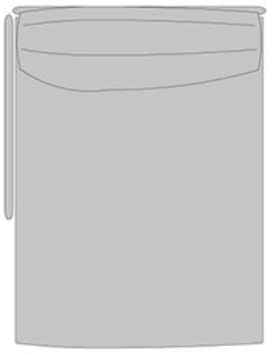

140 cm
55.3 "

100 cm
39.3 "

105 cm
41.5 "

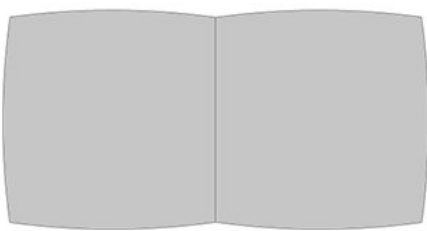
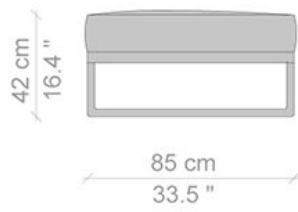

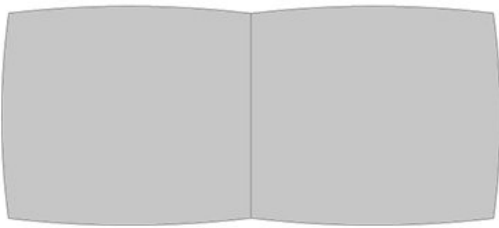
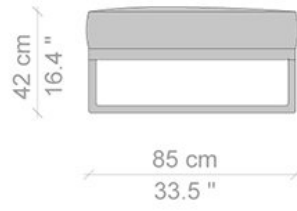
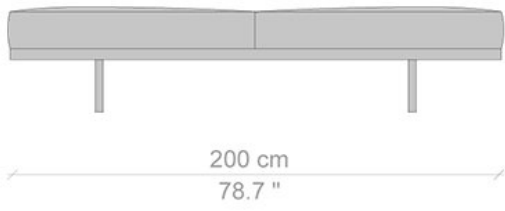

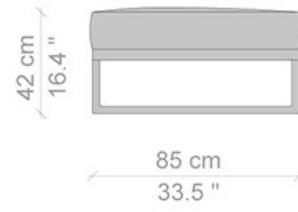
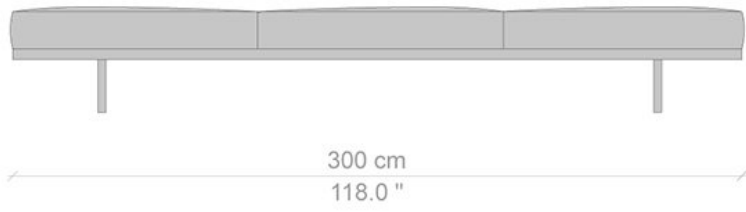
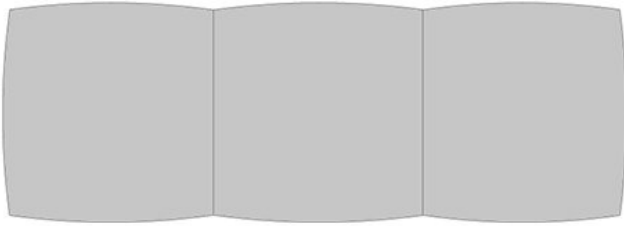
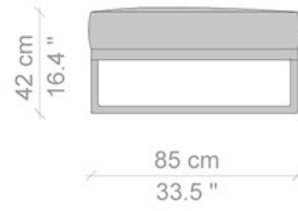



100 cm
39.4 "



26 cm
10.3 "

42 cm
16.6 "

100 cm
39.4 "

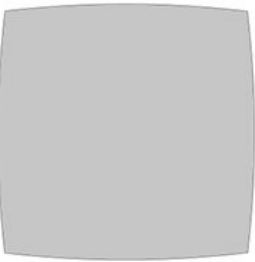

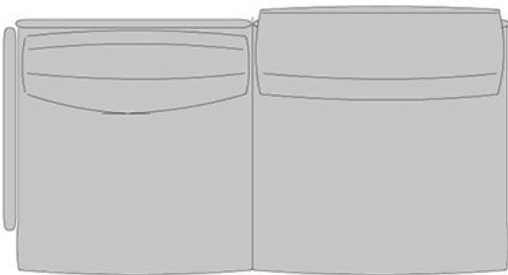
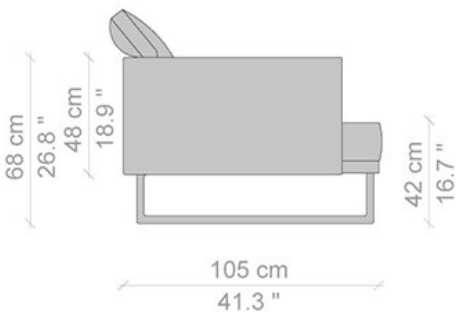
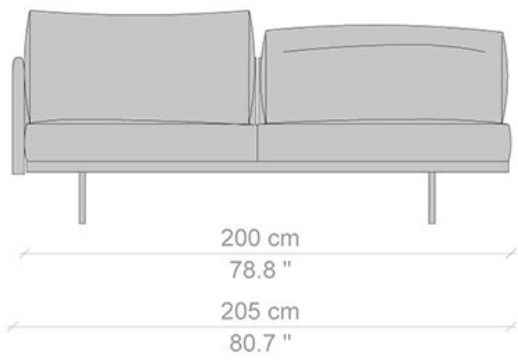
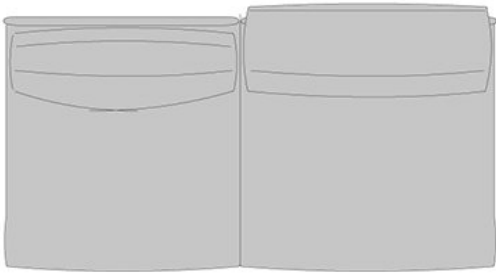
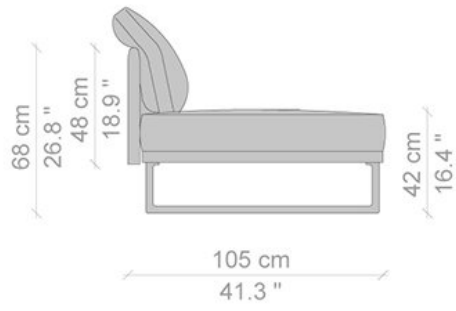

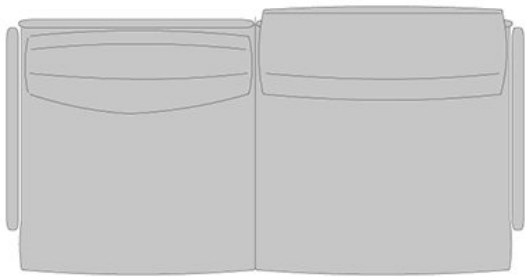
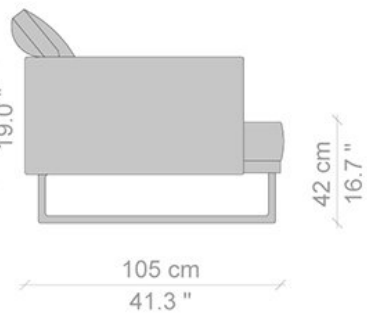
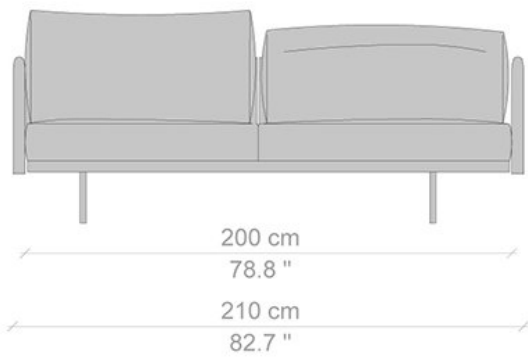

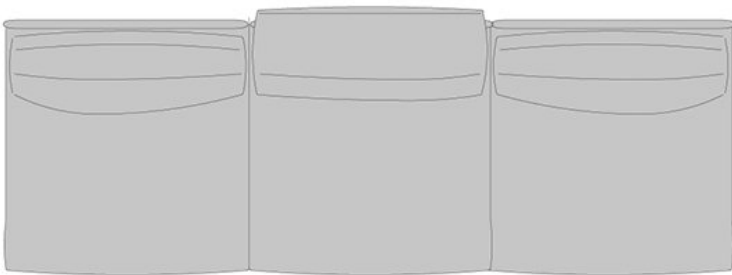
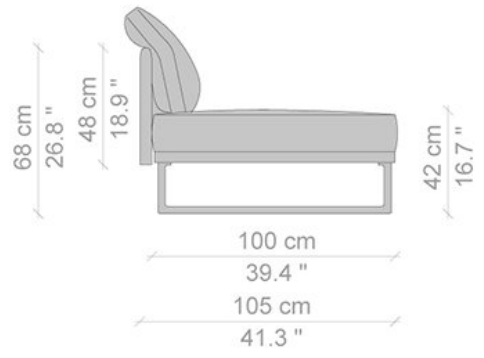
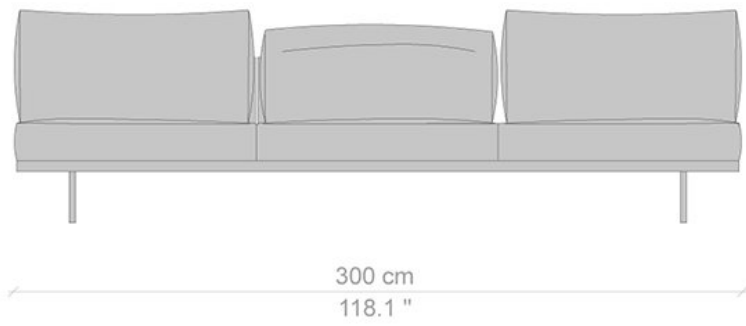

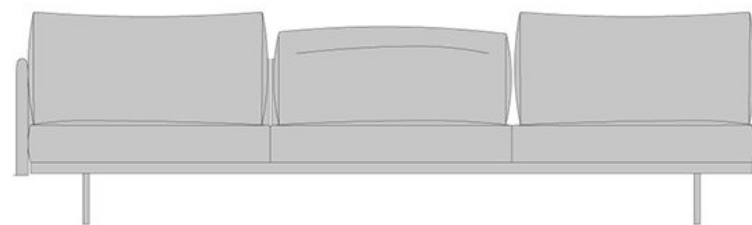

300 cm
118.1 "

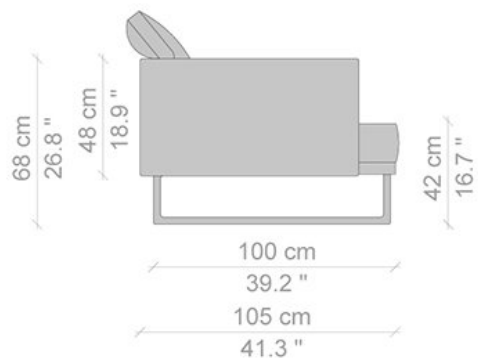

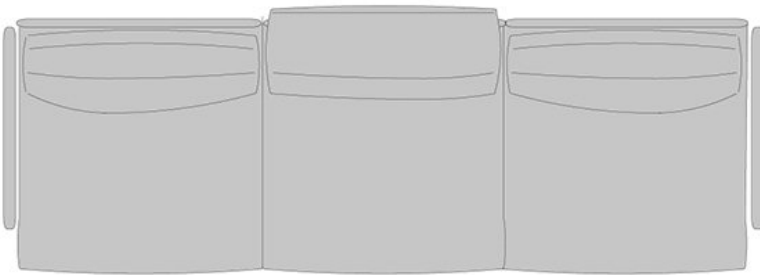

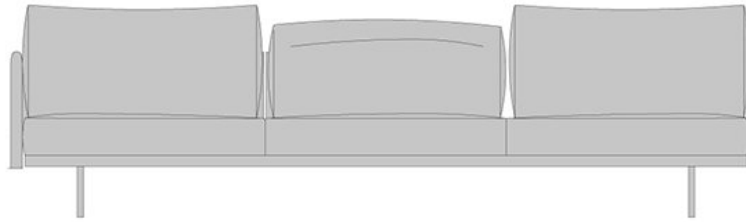

300 cm
118.1 "

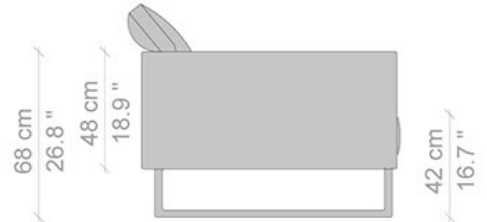

68 cm
26.8 "

48 cm
18.9 "

42 cm
16.7 "

100 cm

39.2 "

105 cm

41.3 "

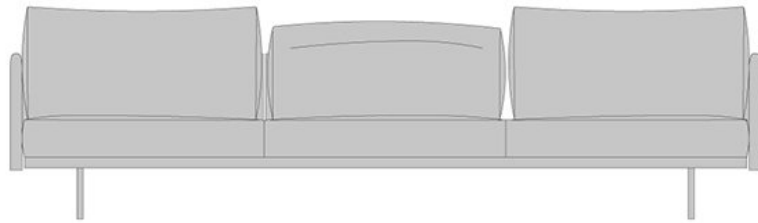
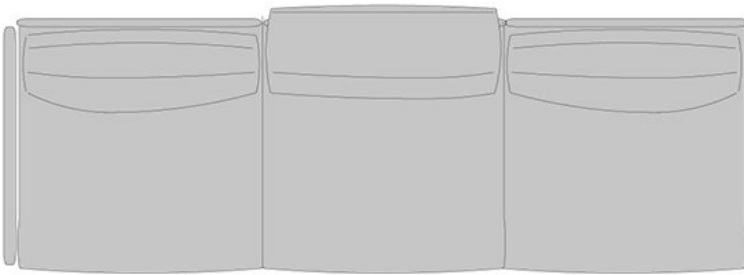

310 cm
122.1 "

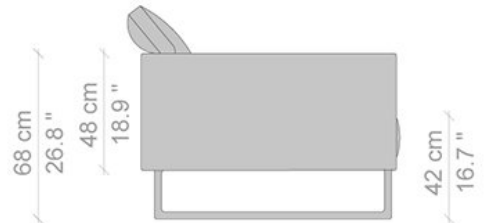

68 cm
26.8 "

48 cm
18.9 "

42 cm
16.7 "

100 cm

39.2 "

105 cm

41.3 "

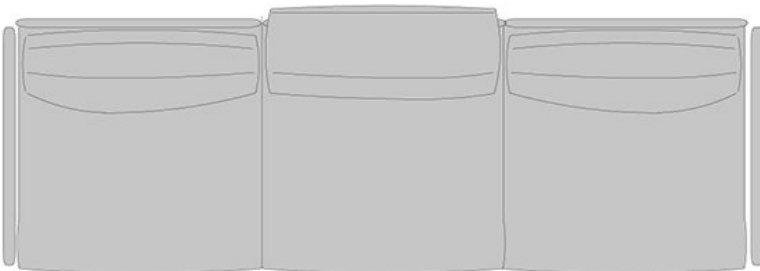



200 cm
78.7 "



100 cm
39.4 "

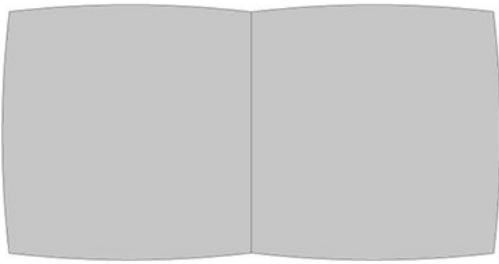

300 cm
118.1 "



100 cm
39.4 "

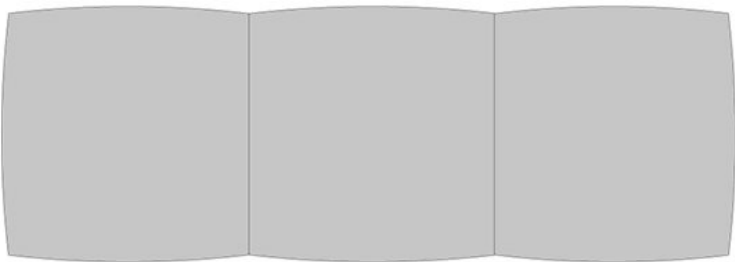



20 cm
8.0 "



105 cm
41.3 "

105 cm
41.3 "

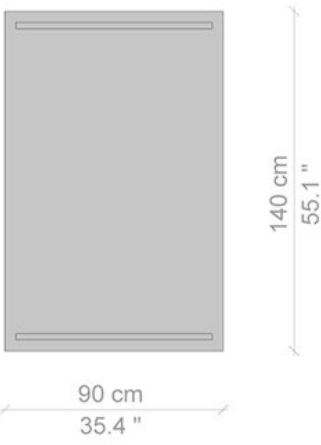

Designer



Piero Lissoni

Piero Lissoni è architetto, art director, designer (1956).

Piero Lissoni apre nel 1986, con Nicoletta Canesi, lo studio Lissoni Associati e inizia collaborazioni che proseguono fino ad oggi con alcune delle migliori aziende di design italiane e internazionali. Lo studio si occupa dei diversi aspetti e sfaccettature del progetto, attraverso la visione professionale inter-disciplinare e umanistica di Piero Lissoni, il cui talento spazia dal design all'architettura.

Nel 1996 nasce Graph.x all'interno dello studio, per lo sviluppo dei progetti di grafica.

Il lavoro dello studio Lissoni Associati comprende progetti d'architettura, di disegno industriale e di grafica, dall'arredamento agli accessori, dalle cucine ai bagni, dall'illuminazione alla corporate identity, attraverso pubblicità, cataloghi e siti web per hotel, showroom, stand fieristici, case private, negozi e barche.

Lo studio, dove lavorano circa 70 persone, progetta per Alessi, Boffi, Cappellini, Cassina, Fantini, Flos/Antares, Fritz Hansen, Glas Italia, Kartell, Knoll International, Lema, Living Divani, Lualdi, Matteograssi, Olivari, Pierantonio Bonacina, Poltrona Frau, Porro, Riva 1920, Sabattini, Tecno e Thonet.

Le incursioni nel campo della moda includono i negozi e le collaborazioni con marchi italiani come Benetton, Brosway, Gallo, Piazza Sempione, Santandrea, Serapian, showroom e corporate identity dello stilista newyorchese Elie Tahari.

Tra le realizzazioni d'architettura recenti si annovera un loft privato a Monza (2009); una villa vicino a Como (2005); abitazioni private e ville a Milano, Monte-Carlo, Tokyo, negli Hamptons e in Toscana; a Gerusalemme il Mamilla Hotel con 210 camere e suite e il ristorante di alta cucina kosher Scala (2009); a Venezia il restauro e gli interni dell'Hotel Monaco & Grand Canal (2002-2004); Bentley Design Hotel™ (2002) a Istanbul; Al Porto Design Hotel™ sul lago di Zurigo (2001); Mitsui Garden Hotel (2005) a Tokyo; Studio M Hotel a Singapore (2010); Hotel Bellariva (2010) un antico palazzo sul Lago di Garda riconvertito in hotel di lusso; le suites principali per il Pierre Hotel a New York (2010) e per The Taj Palace Hotel (2010) a Mumbai.

Oltre a numerosi showroom per Boffi, Cassina, Porro e Tecno, Piero Lissoni ha completato la sede di Living Divani ad Anzano del Parco (2007), le sedi Glas (2010) e Matteograssi (2011) nei dintorni di Milano; la sede per il gruppo La Rinascente a Milano (2006), lo Store Benetton di 8 piani a Istanbul (2009).

Lissoni ha restaurato a Milano lo storico Teatro Nazionale (2009) per il gruppo olandese Stage Entertainment, oggi esclusivamente dedicato al Musical.

In collaborazione con lo Studio Brenta Yacht Design, Lissoni ha realizzato gli interni della barca a vela Ghost 27m (2005) per un collezionista di New York; con il cantiere Mondo Marine ha progettato lo yacht Tribù 50m per Luciano Benetton (2007).

Graph.x cura l'immagine coordinata, logo e manifesti della Mostra Internazionale d'Arte Cinematografica di Venezia dalla 64ima edizione (2007-2011).

I progetti inaugurati di recente includono la ristrutturazione della Club House Ferrari sulla pista di Fiorano; il laboratorio di Pasticceria del ristorante Filippo La Mantia e le sale storiche da ricevimento (Salone Verdi e Sala Mozart) interamente rinnovate all'interno dell'Hotel Majestic a Roma; appartamenti e ville private in Svizzera e in Italia, negozi e showroom a Parigi, Londra, Francoforte, Milano.

I progetti in procinto di essere inaugurati includono Conservatorium Hotel nell'area del Museum Square ad Amsterdam; l'albergo e beauty farm Mare Pineta a Milano Marittima; Grand Hotel Billia a Saint Vincent con annesso il Casinò; David Citadel Hotel a Gerusalemme con un restyling dell'architettura d'interni, le Cantine Sant'Orsola in Piemonte vicino ad Alba.

Nell'Aprile 2010 lo studio ha vinto il concorso ad inviti indetto dal Comune di Maranello per la riqualificazione della piazza e la costruzione della torre panoramica alta 30 metri interamente rivestita in policarbonato, antistanti la Galleria Ferrari.