

# Cassina

## 551 SUPER BEAM SOFA SYSTEM

Year of production **2017**

Beam Sofa System has evolved into a new version whose increased dimensions makes for a higher impact result. Super Beam sofa system also enriches the Beam Sofa System range, further accentuating its modular aspect, its elegance, its high quality and sophisticated details. Its generosity is also expressed through its supreme comfort, made possible by the masterful use of polyester wadding and polyurethane foam. Like Beam, Super Beam develops upon the same geometric beam, the model's distinctive aesthetic feature. This beam makes it possible to create innumerable configurations by bringing together the padded elements and combining them in harmony with the utmost style and functionality. Four modular padded elements, left or right end section, middle section, corner and chaise longue, create a simple arrangement, which can be combined in multiple configurations. The elements are designed with greater depth and thicker padding for even better levels of comfort. The soft and welcoming cushions still stand out for their distinctive edge stitching which is embellished with a "curl", an additional aesthetic element created with the excess leather or fabric that is carefully distributed during the stitching process to form elegant folds on the front of the seat and on the upper part of the backrest to exalt their sophistication and elegance. The system is completed by an independent chaise longue and a series of side tables: • Rectangular in shape, which can be combined with the middle or end padded elements; • Independent, consisting of a base with two surfaces, one rectangular and one round, in different finishes, at two different levels. Structure: tubular steel. Padding: variable density CFC-free polyurethane foam and polyester wadding. Base: aluminium lacquered in black or chestnut brown. Feet: transparent plastic. Removable fabric or leather upholstery. Side Table Finishes: American walnut, natural oak, black stained oak, cement-stone.

## Gallery



## Dimensions

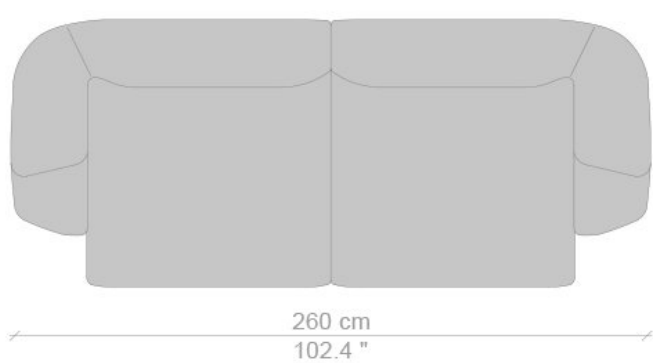

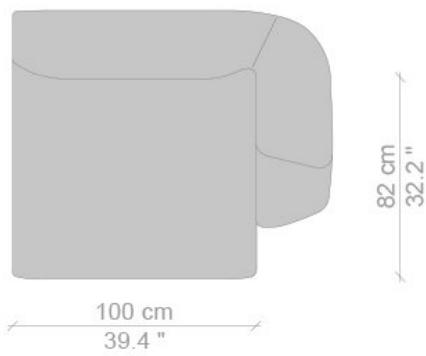
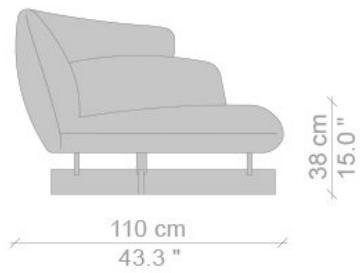
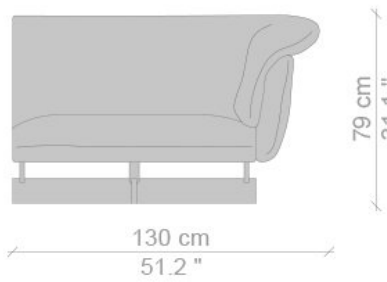
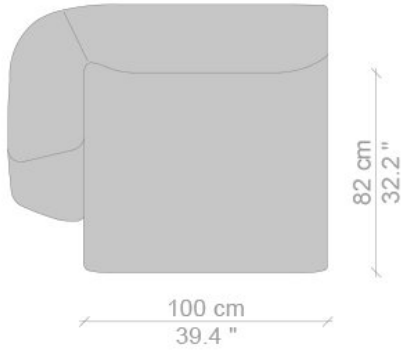
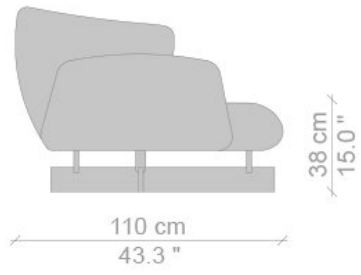
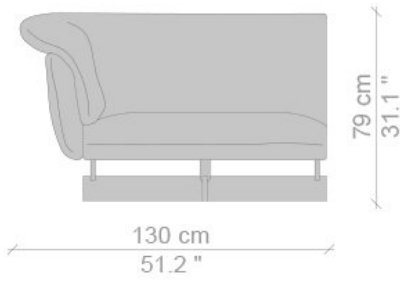

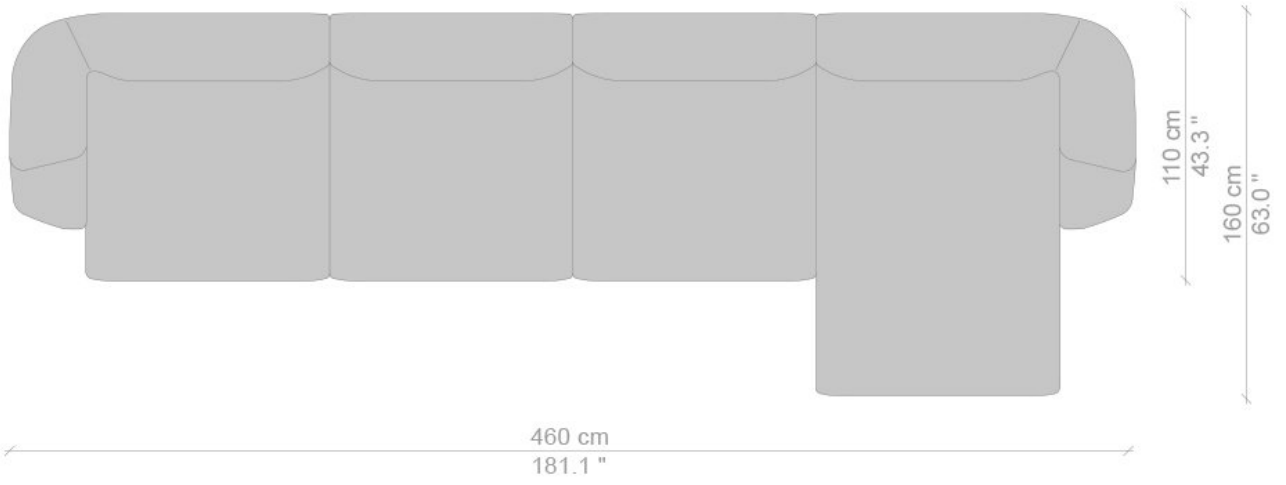
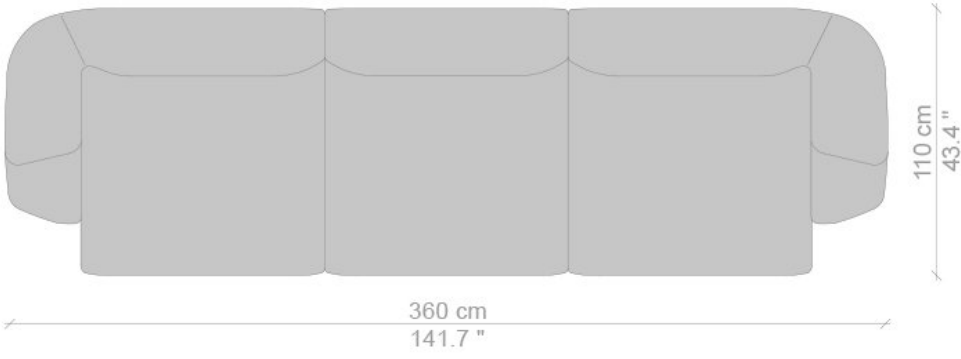

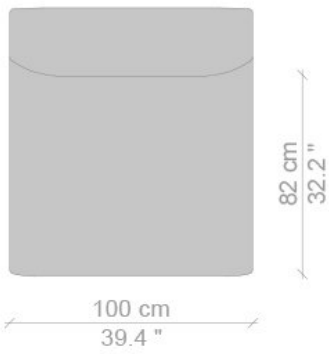
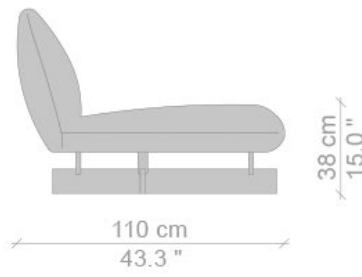
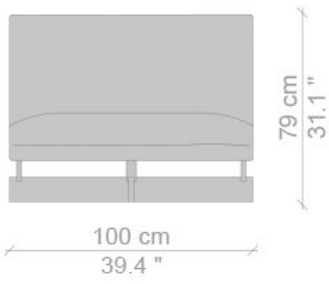

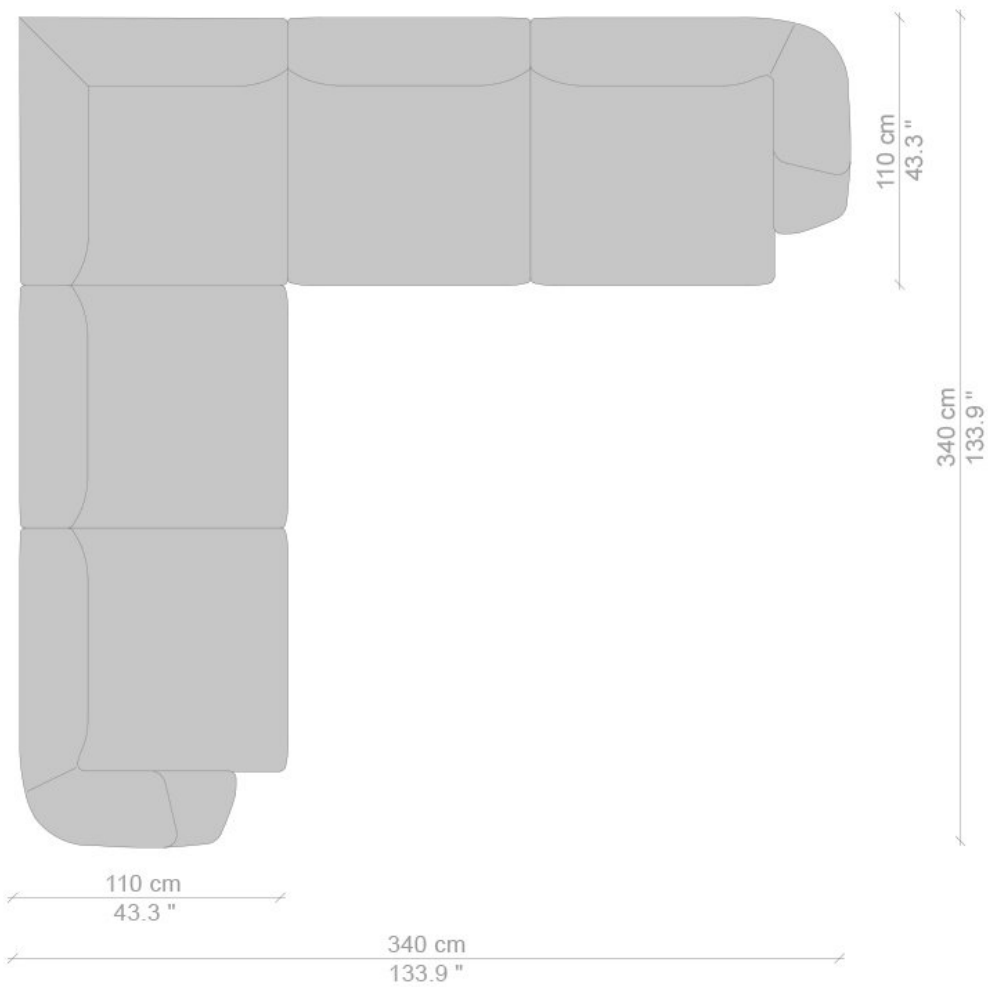

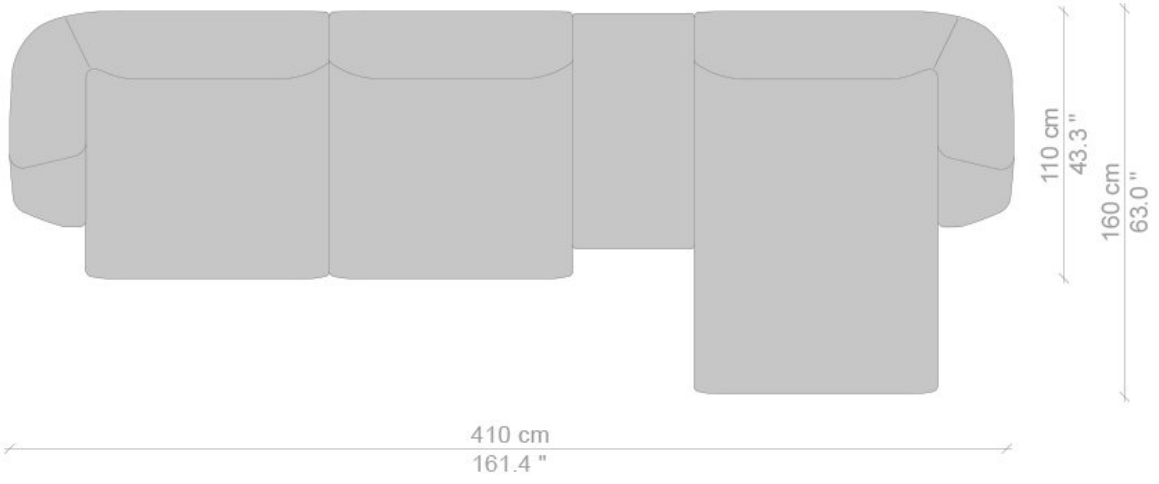
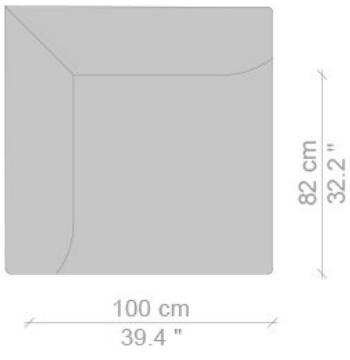
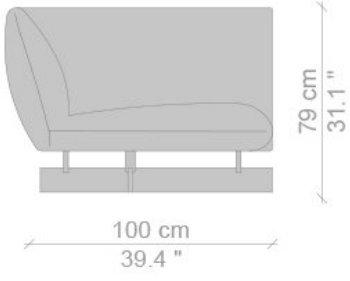

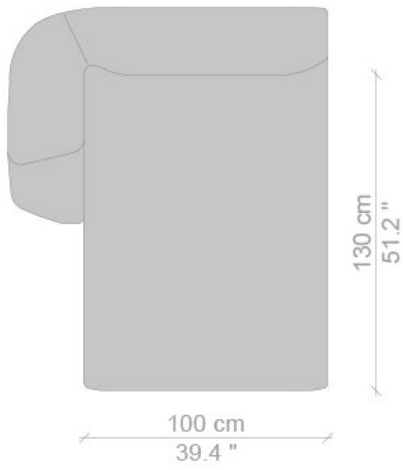
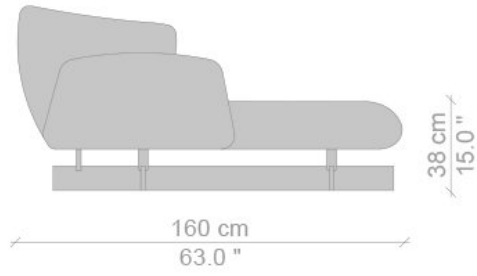
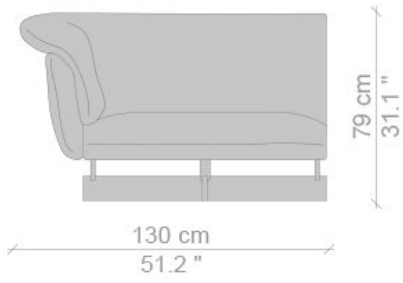



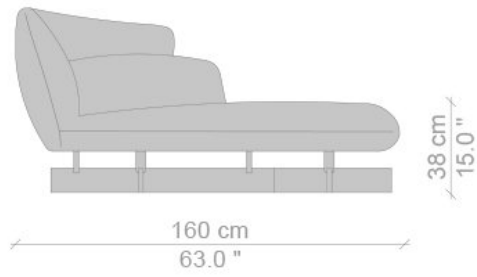
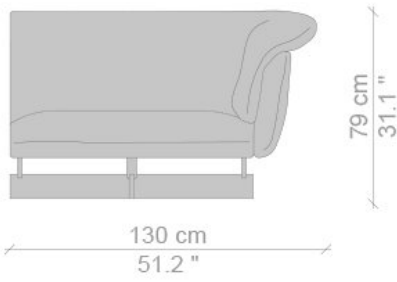

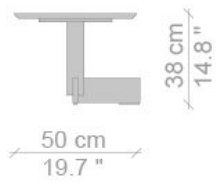
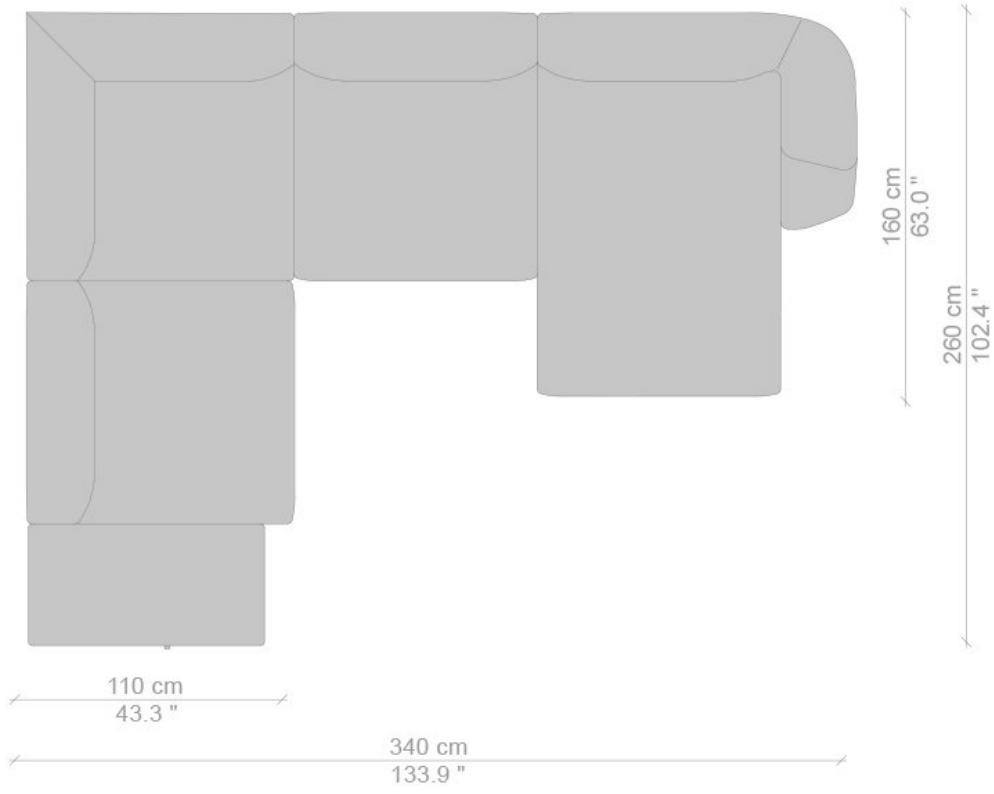

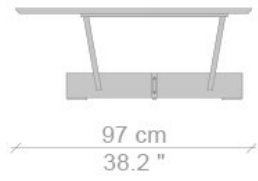
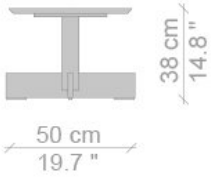
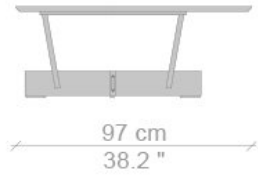
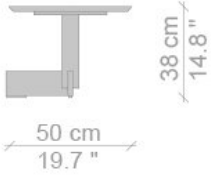

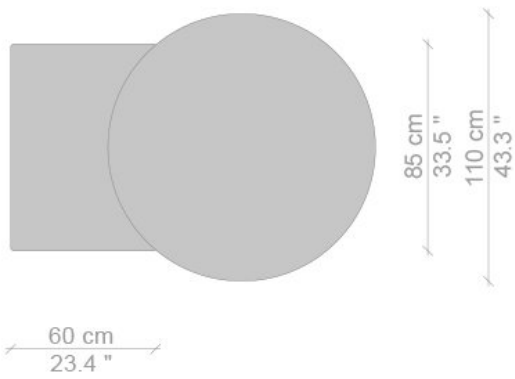
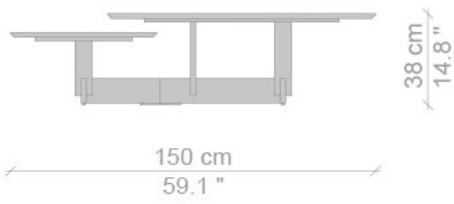
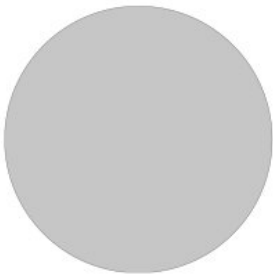
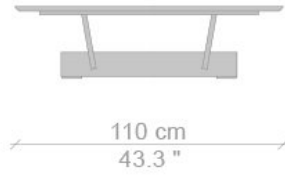

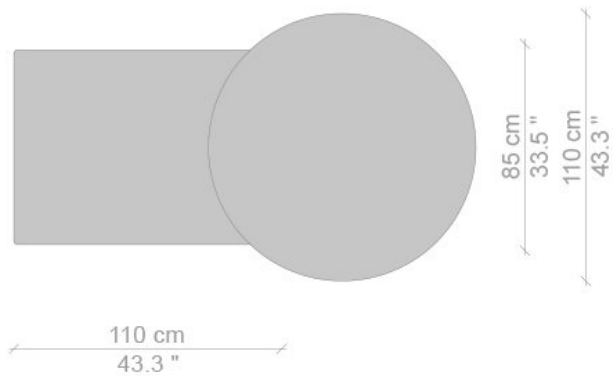
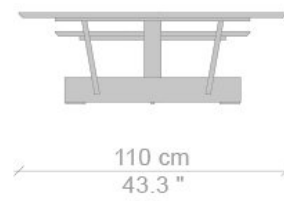
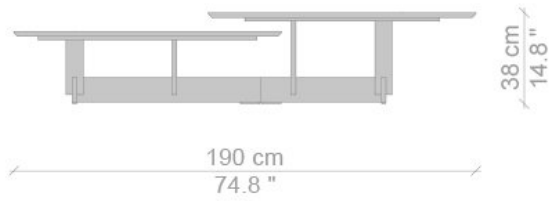

## Designer



**Patricia Urquiola**

*Patricia Urquiola was born in Oviedo (Spain) in 1961. Lives and works in Milan. She attended the University of Architecture at Madrid Polytechnic and Milan Polytechnic, where she graduated in 1989 with Achille Castiglioni. Assistant lecturer to Achille Castiglioni and Eugenio Bettinelli in Milan and Paris, responsible for the new product development office of DePadova, working with Vico Magistretti, head of Lissoni Associati's design group. In 2001 she opened her own studio working on product design, architecture, and installations. Amongst her last projects of architecture: The museum of Jewel in Vicenza, Mandarin Oriental Hotel in Barcelona, das Stue Hotel in Berlin and the Spa of Four Seasons Hotel in Milan; showroom and installations for Gianvito Rossi, BMW, Cassina, Missoni, Moroso, Molteni, Officine Panerai, H&M, Santoni and the general concept of Pitti Immagine Firenze. She realize design products for the most important Italian and international companies, such as : Agape, Alessi, Axor-Hansgrohe, B&B Italia, Baccarat, Boffi, Budri, De Padova, Driade, Ferragamo, Flos, Gan, Georg Jensen, Glas Italia, Haworth, Kartell, Kettal, Kvadrat, Listone Giordano, Louis Vuitton, Molteni, Moroso, Mutina, Rosenthal and Verywood. Some of her products are exposed in various Museums and collections, such as MoMA in New York, Les arts decoratifs in Paris, the Museum of Design in Zurich, Vitra Design Museum in Basel, Victorian&Albert Museum in London, Stedelijk in Amsterdam and Triennale Museum in Milan. She has won several international prices and awards. Amongst others the Medalla de Oro al Mérito en las Bellas Artes (Gold Medal of fine arts) awarded by the Spanish Government; Order of Isabella the Catholic, awarded by His Majesty The King of Spain Juan Carlos I; "Designer of the decade" for two German magazines, Home and Häuser, "Designer of the Year" for Wallpaper, Ad Spain, Elle Decor International and Architektur und Wohnen Magazine. She is Ambassador of Expo Milano 2015. September 2015 Patricia Urquiola nominated Art Director of Cassina.*