

Cassina

499 ORDINAL

Year of design **2018**

A collection of dining tables, both contemporary and sculptural, where the designer's expertise in metalwork comes together with Cassina's crafts skills and excellence in carpentry work. This clean-cut, essential design consists of a slender table-top fitted onto super-slim legs, in wood, or anodised or painted aluminium. Set at the very end of the table-top, and diagonally to it, the legs afford extra space to the guests. This design was especially challenging to Cassina's Research Unit, and they responded by creating an innovative solution that is not only stable, but also strong while taking up minimal space. The collection includes two square tables as well as one oval option with a lacquered or veneer top and a solid wood trim. There are also three rectangular versions, one of which is in solid wood. The latter includes a concealed metal mechanism designed to counter the tensions and movements of the wood over time. The models with veneered tops have precious edges in solid wood.

Gallery



Dimensions

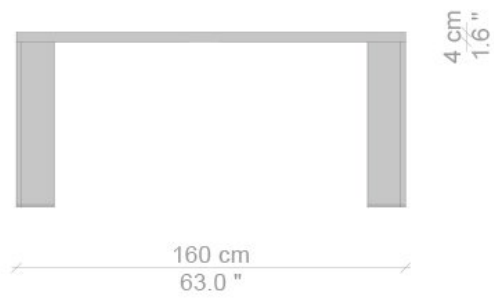
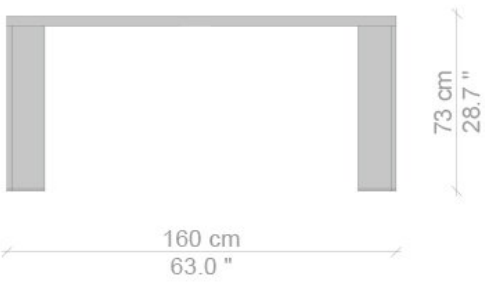
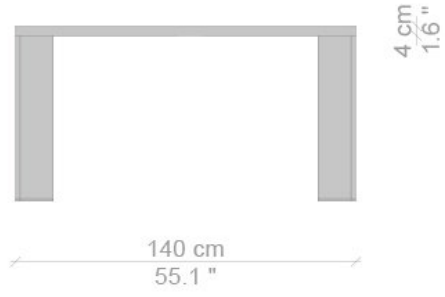
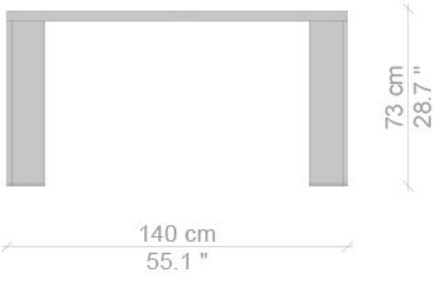

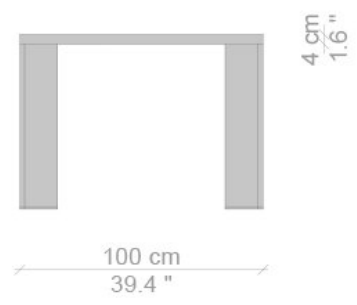
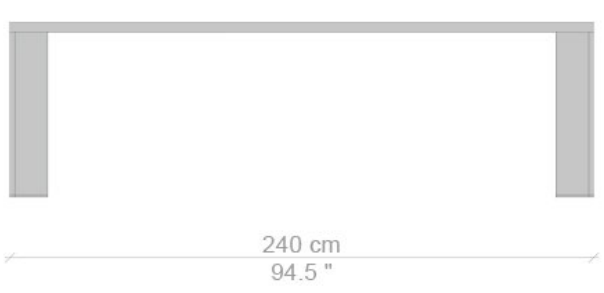
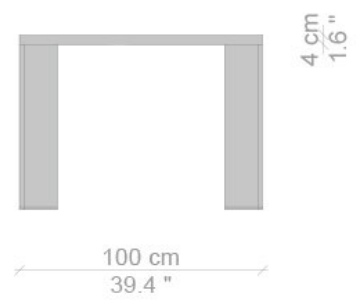
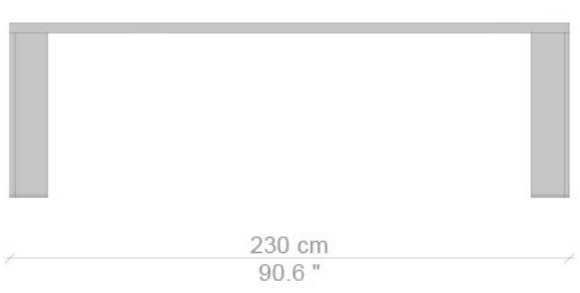

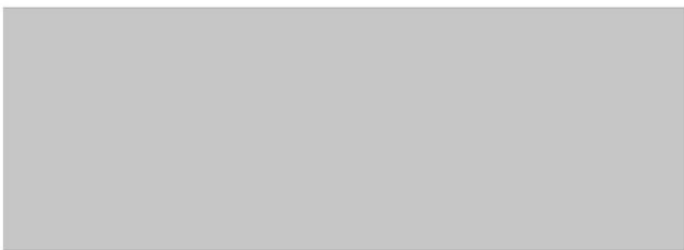
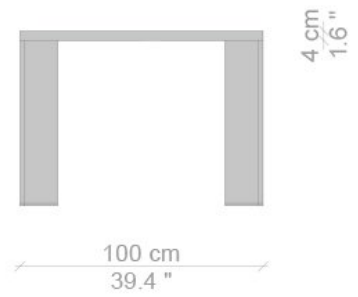
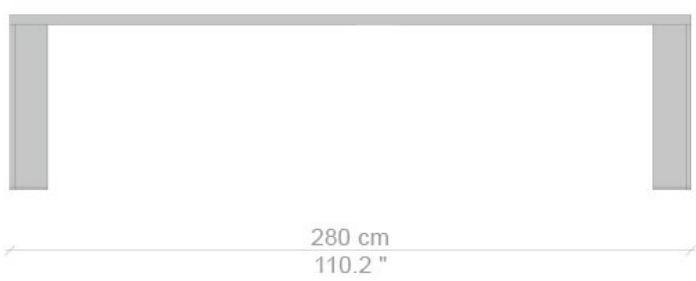
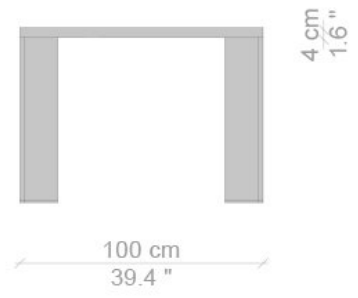
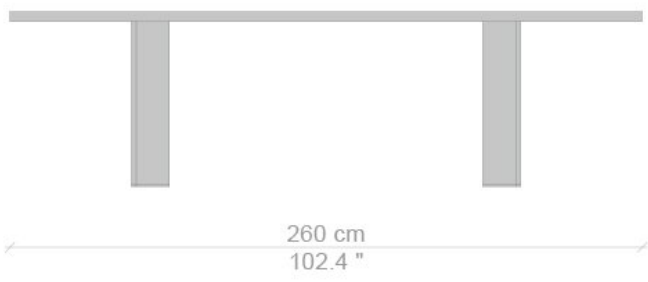

Designer



Michael Anastassiades

Michael Anastassiades is a Cypriot designer, based in London. He launched his studio in 1994 to explore contemporary notions of culture and aesthetics through a combination of product, furniture and environmental design. Positioned between fine art and design, his work aims to provoke dialogue, participation and interaction. He creates objects that are minimal, utilitarian and almost mundane yet full of a vitality one might not expect. Anastassiades' work is featured in permanent collections at the Museum Of Modern Art in New York, the Victoria and Albert museum, the Crafts Council in London, the FRAC Centre in Orleans France and the MAK in Vienna. Recent solo exhibitions include Time And Again at the Geymüllerschloss/MAK in Vienna, To Be Perfectly Frank at Svenskt Tenn in Stockholm, Norfolk House music room at the Victoria & Albert museum in London, Cyprus Presidency at the European Parliament in Brussels Belgium, Atelier Jesper Brussels . He has designed products with various leading manufacturers including Flos, Puiforcat, Lobjoy and Svenskt Tenn. In 2007 he set up Michael Anastassiades the company to produce his signature pieces, a collection of lighting, furniture, jewellery and tabletop objects. The studio's philosophy is a continuous search for eclecticism, individuality and timeless qualities in design. Michael trained as a civil engineer at London's Imperial College of Science Technology and Medicine before taking a masters degree in industrial design at the Royal College of Art.