

Cassina

DECO

Cataloghi **SimonCollezione**

Anno di produzione **1971**

Il mobile è componibile e sovrapponibile ed è verniciato a poliestere con finitura lucida specchiante o opaca. Disponibile in diverse dimensioni, nelle versioni a giorno, con ante, con due o tre cassetti.

Gallery



Dimensioni

108 cm
42.5 "

55 cm
21.8 "

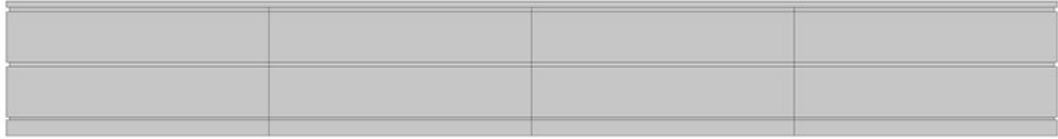

432 cm
170.1 "

42 cm
16.5 "

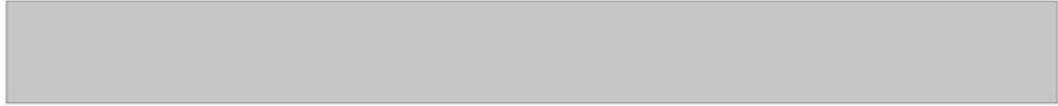

55 cm
21.8 "



432 cm
170.1 "

42 cm
16.5 "

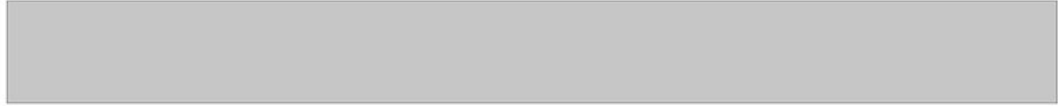

108 cm
42.5 "

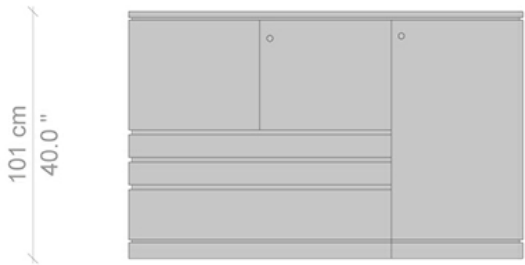

162 cm
63.8 "

42 cm
16.5 "

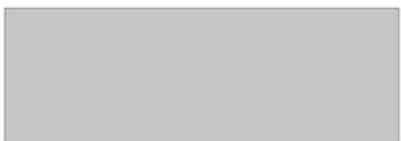

108 cm 54 cm 108 cm
42.5 " 21.3 " 42.5 "

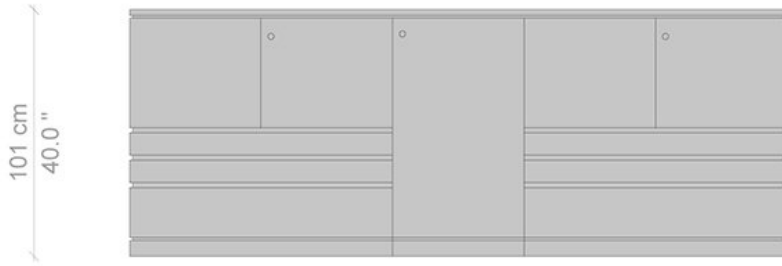

270 cm
106.3 "

42 cm
16.5 "

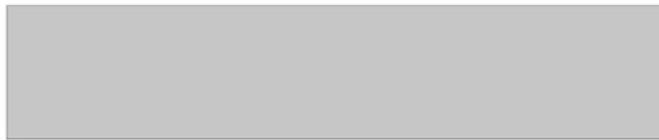

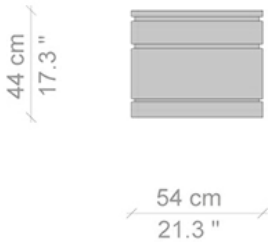
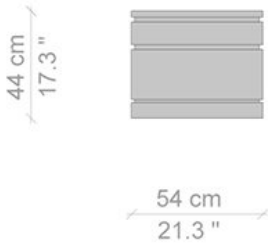

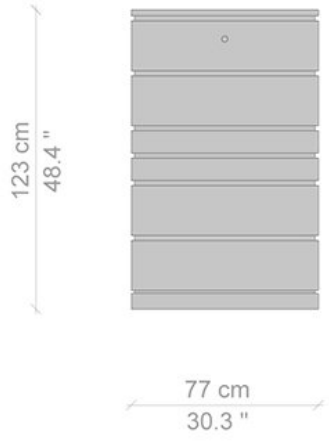
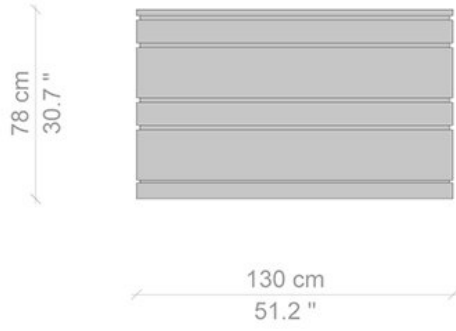

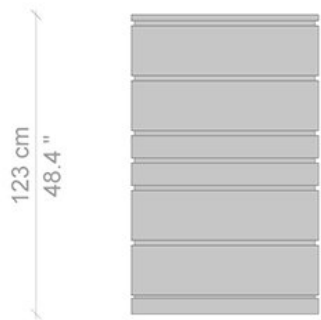

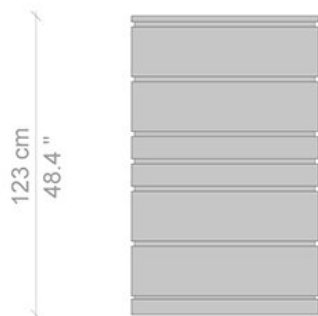
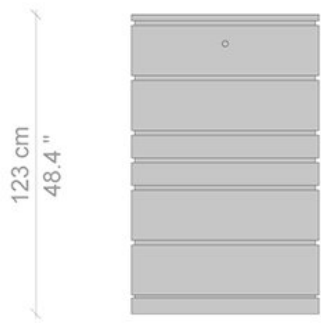

Designer



Studio Simon

Dino Gavina, (1922-2007), inizia la sua attività già a partire dagli anni '40 con oggetti per le scene di teatro, sua grande passione.

Convinto della necessità di un design moderno ma anche ricco di poesia, gradualmente riesce a coinvolgere molti "padri della patria", come li chiama scherzosamente, tra cui Carlo Scarpa, Enzo Mari, Marcel Breuer, solo per citarne alcuni. Il suo lavoro costituisce il punto di partenza del cosiddetto Italian Style, un sinonimo di qualità che da allora accompagna il design italiano di mobili in tutto il mondo.