

Cassina

499 ORDINAL

Anno di progettazione **2018**

Una collezione di tavoli da pranzo contemporanei e sculturali, in cui la tipica lavorazione in metallo dell'autore si unisce all'artigianalità e alla competenza della falegnameria Cassina. Il design pulito ed essenziale abbina un piano in legno di minimo spessore alle gambe sottili, in legno o in alluminio anodizzato o verniciato, poste in diagonale alle estremità del tavolo per garantire maggiore spazio ai commensali. Una sfida estrema per il Centro Ricerche dell'azienda, che ha saputo elaborare una soluzione innovativa in grado di coniugare stabilità, resistenza e spessori ridotti. L'offerta prevede due versioni quadrate, una ovale con piano laccato o impiallacciato, e due versioni rettangolari di cui una in legno massello. Quest'ultima è integrata con un meccanismo metallico regolabile, nascosto nella parte inferiore del piano, che consente di contrastare le tensioni e i movimenti del legno. I modelli con piani impiallacciati presentano preziosi bordi in legno massello.

Gallery



Dimensioni

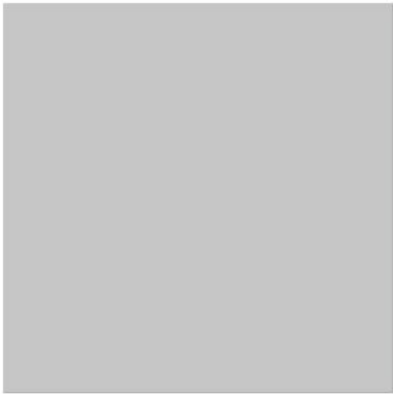
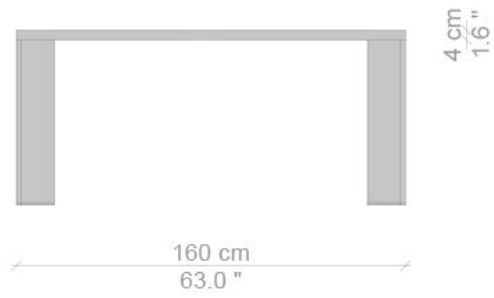
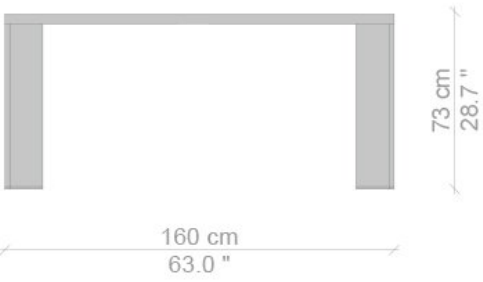
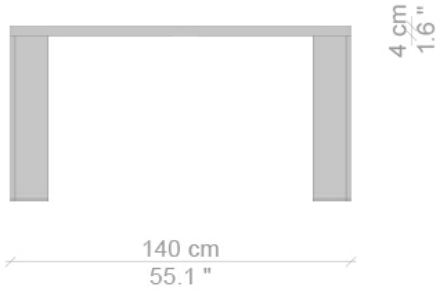
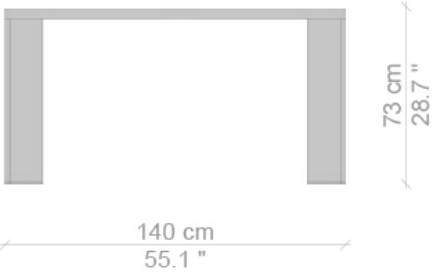

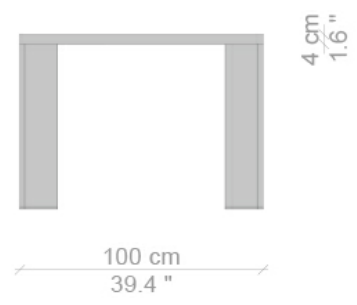
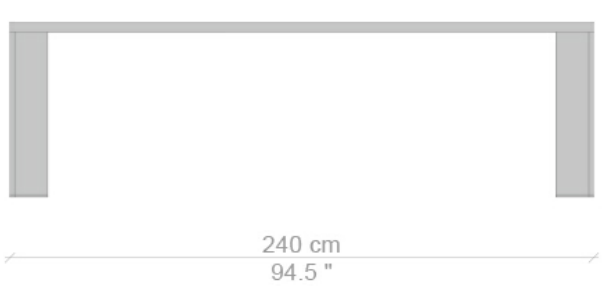
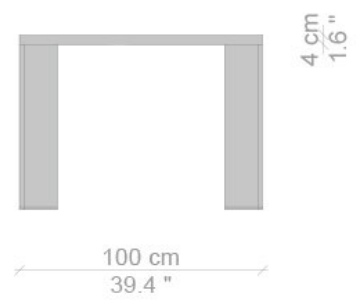
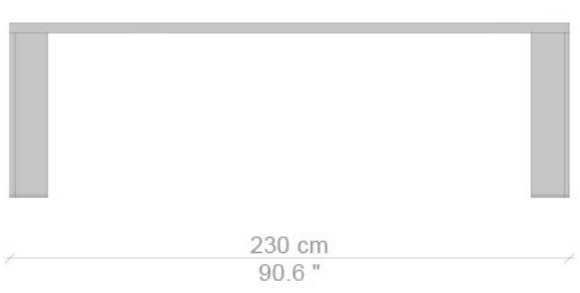

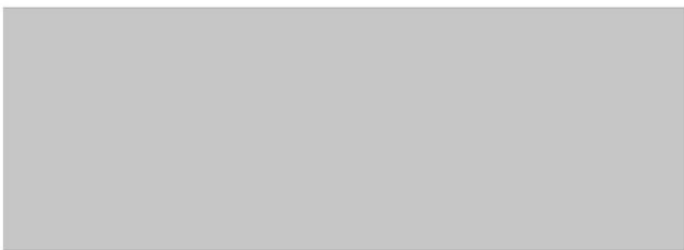
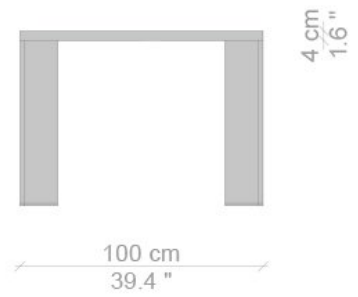
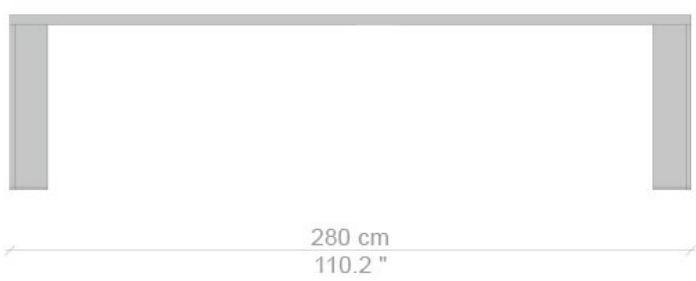
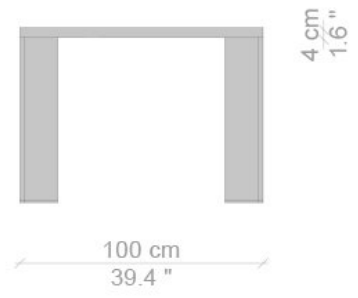
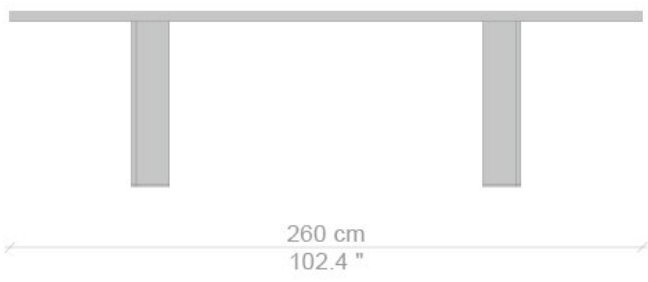

Designer



Michael Anastassiades

Michael Anastassiades is a Cypriot designer, based in London. He launched his studio in 1994 to explore contemporary notions of culture and aesthetics through a combination of product, furniture and environmental design. Positioned between fine art and design, his work aims to provoke dialogue, participation and interaction. He creates objects that are minimal, utilitarian and almost mundane yet full of a vitality one might not expect. Anastassiades' work is featured in permanent collections at the Museum Of Modern Art in New York, the Victoria and Albert museum, the Crafts Council in London, the FRAC Centre in Orleans France and the MAK in Vienna. Recent solo exhibitions include Time And Again at the Geymüllerschloss/MAK in Vienna, To Be Perfectly Frank at Svenskt Tenn in Stockholm, Norfolk House music room at the Victoria & Albert museum in London, Cyprus Presidency at the European Parliament in Brussels Belgium, Atelier Jesper Brussels . He has designed products with various leading manufacturers including Flos, Puiforcat, Lobjoy and Svenskt Tenn. In 2007 he set up Michael Anastassiades the company to produce his signature pieces, a collection of lighting, furniture, jewellery and tabletop objects. The studio's philosophy is a continuous search for eclecticism, individuality and timeless qualities in design. Michael trained as a civil engineer at London's Imperial College of Science Technology and Medicine before taking a masters degree in industrial design at the Royal College of Art.